

Submersible sump pumps suitable for draining garages, cellars and other places subjected to flooding and for garden ponds and small water displays. They can be applied for portable and fixed installations. Supplied with 5 mts.cable lenght type H05 RN-F and available with or without float switch. (10 mts. cable H05 RN-F on request)



SPECIFICATIONS

- Maximum liquid temperature:
35°C according EN 60335-2-41 for domestic uses
40°C for other uses
- Maximum immersion: 5 mts
- Maximum passage of solids: 10 mm

TECHNICAL DATA

- Asincronous 2 poles motor
- Insulation class F
- Protection degree IP68
- 1~230V +- 10% 50Hz
- DNM 1³/₄

MATERIALS

- Pump casing, strainer, cover and motor casing in AISI 304
- Impeller, diffuser and spacer in tecnopolymer
- Shaft in AISI 304
- Grease lubricated double lip seal

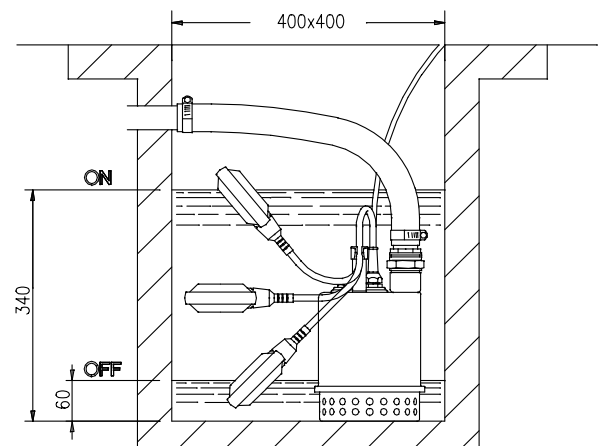
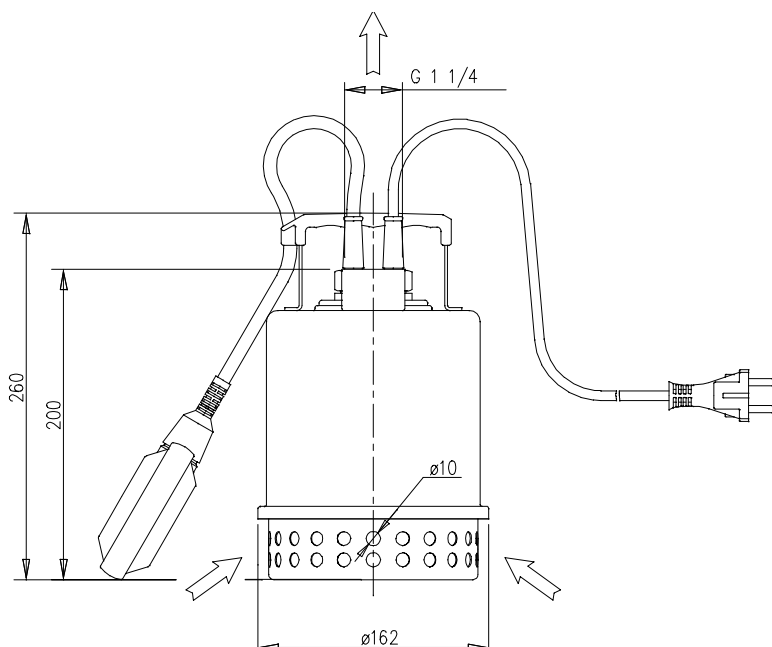

PERFORMANCE CURVE (according to ISO 9906 grade 2)

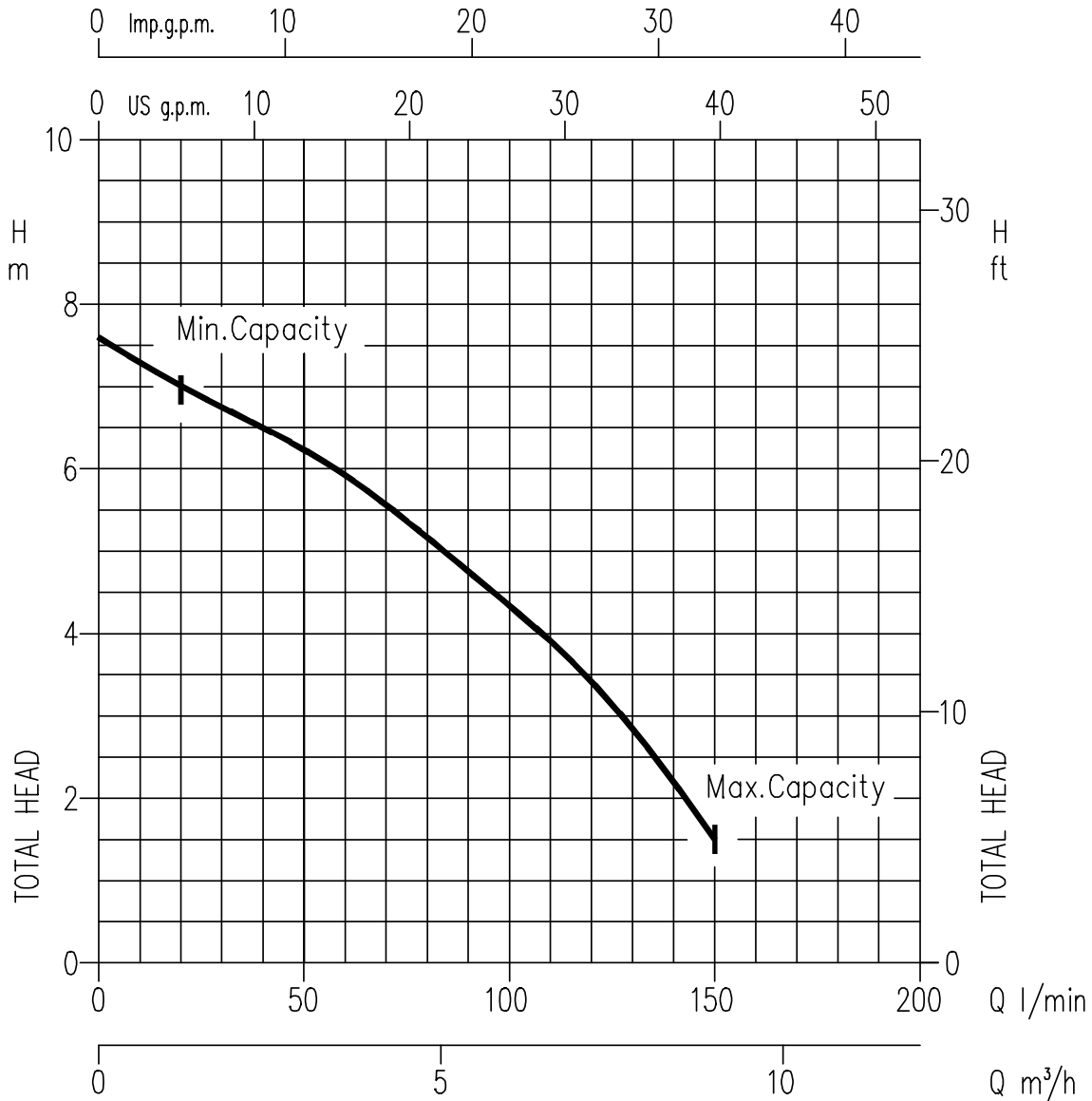

PERFORMANCE TABLE

Pump type Single-phase 230V 50Hz	kW	Capacitor		Abs. Curr. (A) Single-phase	l/min m³/h	Q=Capacity						Pump type Single-phase 230V 50Hz	Weight kg
		µF	V _c			20	50	75	100	125	150		
BEST ZERO	0,25	8	450	1,9		1,2	3	4,5	6	7,5	9	BEST ZERO	4,5
BEST ZERO SG	0,25	8	450	1,9		7	6,3	5,4	4,3	3,1	1,5	BEST ZERO SG	5,3