



### **BEST BOX** (Shower and Washbasin version)

- Predisposed to pump type Best one
- Free passage: 10 mm
- Outlet diam. 1<sup>3</sup>/<sub>4</sub>"
- Tank capacity: 30 l
- Weight without pump: 8,5 kg



### **BEST BOX** (Garage version)

- Predisposed to pump type Best one Vox
- Free passage: 20 mm
- Outlet diam. 1<sup>3</sup>/<sub>4</sub>"
- Tank capacity: 30 l
- Weight : 125 kg

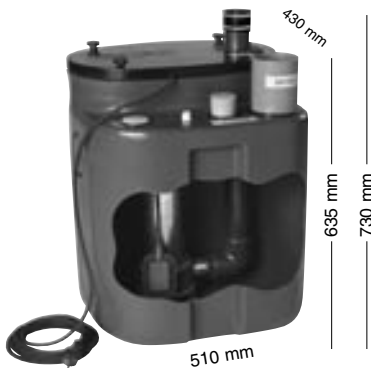

### **MINI RIGHT**

- Predisposed to pump type Right series
- Free passage: 35 mm
- Outlet diam. 50 mm
- Tank capacity: 100 l
- Weight: 26 kg



### **SANIRELEV 11**

- Predisposed to pump type DW or DW VOX
- Free passage: 50 mm
- Outlet diam. DN50/DN63
- Tank capacity: 360 l
- Weight: 21,5 kg

**Sanirelev 11 MSA:** single-phase, support and float switch

**Sanirelev 11 MPA:** single-phase, foot bracket and float switch

**Sanirelev 11 MSC:** single-phase, support, panel and float switch

**Sanirelev 11 MPC:** single-phase, foot bracket, panel and float switch

**Sanirelev 11 TSC:** three-phase, support, panel and float switch

**Sanirelev 11 TPC:** three-phase, foot bracket, panel and float switch



### **SANIRELEV 22**

- Predisposed to two pumps type DW or DW VOX
- Free passage: 50 mm
- Outlet diam. DN50/DN63
- Tank capacity: 540 l
- Weight: 30 kg

**Sanirelev 22 MPC:** single-phase, foot bracket, panel and float switch

**Sanirelev 22 TPC:** three-phase, foot bracket, panel and float switch