

6" deep-well pumps entirely made of stainless steel AISI 304. The smooth surface of the impellers and diffusers offer an improved efficiency, and reliability factor. Applications include clean water extraction from boreholes, pressure boosting for domestic, farming and industrial applications. Installation can be horizontal as well as vertical. The 6BHS can be fitted to any NEMA standard motor.



SPECIFICATIONS

- Maximum immersion: 100 m (oil motor)
350 m (water motor)
- Maximum liquid temperature: 30°C
- Maximum sand content: 50 ppm

MATERIALS

- Bracket, suction and discharge ports, coupling, impeller, diffuser, diffuser cover, valve, tie-rod and cable guard in AISI 304
- Liner ring in EPDM/AISI 304
- Shaft in AISI 316

TECHNICAL DATA

- 2 poles motor, water filled (W version) or oil filled (O version)
- Maximum startings/hour: 25 (O version)
20 (W version)
- Insulation class F
- Protection degree IP58
- 3~380/400V - 400 (+6% -10%), 50Hz

PERFORMANCE CURVES (according to ISO 9906 grade 2)

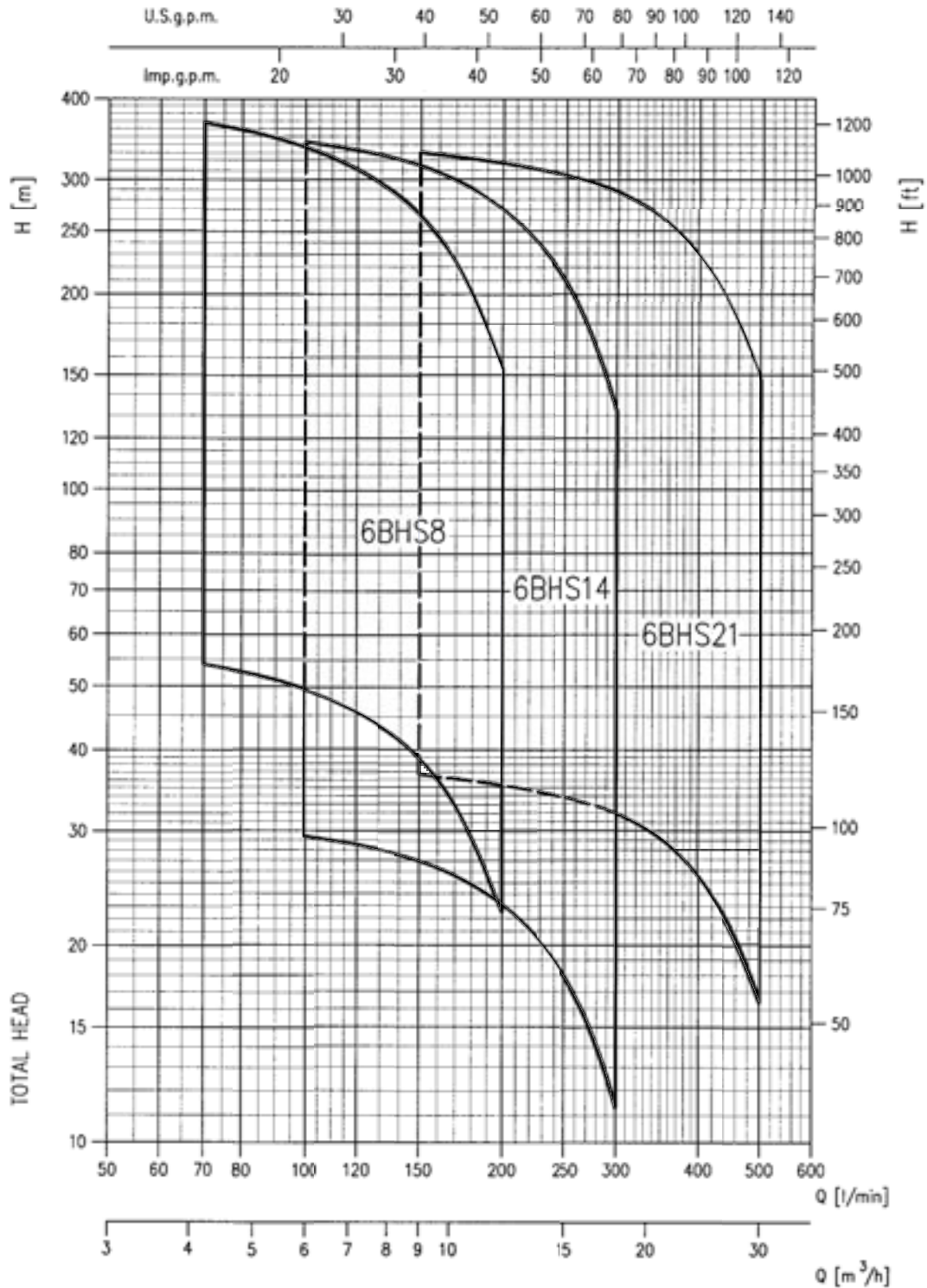

PERFORMANCE TABLE

Pump Type 6BHS	Motor size	kW	HP	Q = Capacity									
				l/min.	70	100	150	200	250	300	375	450	500
					m ³ /h	4,20	6,0	9,0	12,0	15,0	18,0	22,5	27,0
H = Total head													
64BHS8 5	4"	1,5	2	54	49,5	39	22,5	-	-	-	-	-	-
64BHS8 7	4"	2,2	3	75,5	69,5	54,5	31,5	-	-	-	-	-	-
64BHS8 10	4"	3	4	108	99	77,5	45	-	-	-	-	-	-
64BHS8 13	4"	4	5,5	140	129	101	58,5	-	-	-	-	-	-
6BHS8 13	6"	4	5,5	140	129	101	58,5	-	-	-	-	-	-
64BHS8 15	4"	5,5	7,5	162	149	116	67,5	-	-	-	-	-	-
6BHS8 15	6"	5,5	7,5	162	149	116	67,5	-	-	-	-	-	-
64BHS8 18	4"	5,5	7,5	194	178	140	81	-	-	-	-	-	-
6BHS8 18	6"	5,5	7,5	194	178	140	81	-	-	-	-	-	-
6BHS8 21	6"	7,5	10	227	208	163	94,5	-	-	-	-	-	-
6BHS8 25	6"	7,5	10	270	248	194	113	-	-	-	-	-	-
6BHS8 29	6"	9,2	12,5	313	287	225	131	-	-	-	-	-	-
6BHS8 34	6"	11	15	367	337	264	153	-	-	-	-	-	-
64BHS14 3	4"	1,5	2	-	29,5	27	23	18	11,5	-	-	-	-
64BHS14 5	4"	2,2	3	-	49	45	38,5	30	19	-	-	-	-
64BHS14 7	4"	3	4	-	68,5	63	54	42	26,5	-	-	-	-
64BHS14 9	4"	4	5,5	-	88	81	69,5	54	34	-	-	-	-
6BHS14 9	6"	4	5,5	-	88	81	69,5	54	34	-	-	-	-
64BHS14 13	4"	5,5	7,5	-	127	117	100	78	49	-	-	-	-
6BHS14 13	6"	5,5	7,5	-	127	117	100	78	49	-	-	-	-
6BHS14 15	6"	7,5	10	-	147	135	116	90	56,5	-	-	-	-
6BHS14 18	6"	7,5	10	-	176	162	139	108	68	-	-	-	-
6BHS14 22	6"	9,2	12,5	-	216	198	170	132	83	-	-	-	-
6BHS14 26	6"	11	15	-	255	234	201	156	98	-	-	-	-
6BHS14 31	6"	15	20	-	304	279	239	185	117	-	-	-	-
6BHS14 35	6"	15	20	-	343	315	270	209	132	-	-	-	-
64BHS21 4	4"	3	4	-	-	36,5	35,5	34	32	27,5	21	16,5	-
64BHS21 6	4"	4	5,5	-	-	55	53	51	48	41,5	32	24,5	-
6BHS21 6	6"	4	5,5	-	-	55	53	51	48	41,5	32	24,5	-
64BHS21 8	4"	5,5	7,5	-	-	73,5	71	67,5	64	55	42	33	-
6BHS21 8	6"	5,5	7,5	-	-	73,5	71	67,5	64	55	42	33	-
6BHS21 12	6"	7,5	10	-	-	110	106	102	96	83	64	49	-
6BHS21 14	6"	9,2	12,5	-	-	128	124	118	112	96	74	57,5	-
6BHS21 17	6"	11	15	-	-	156	150	144	136	117	90	69,5	-
6BHS21 22	6"	15	20	-	-	202	194	186	176	151	117	90	-
6BHS21 25	6"	15	20	-	-	229	221	212	200	172	133	103	-
6BHS21 29	6"	18,5	25	-	-	266	256	245	232	200	154	119	-
6BHS21 34	6"	22	30	-	-	312	300	288	272	234	180	139	-
6BHS21 36	6"	22	30	-	-	330	318	305	288	248	191	148	-

PERFORMANCE CURVES 6BHS8 series (according to ISO 9906 grade 2)

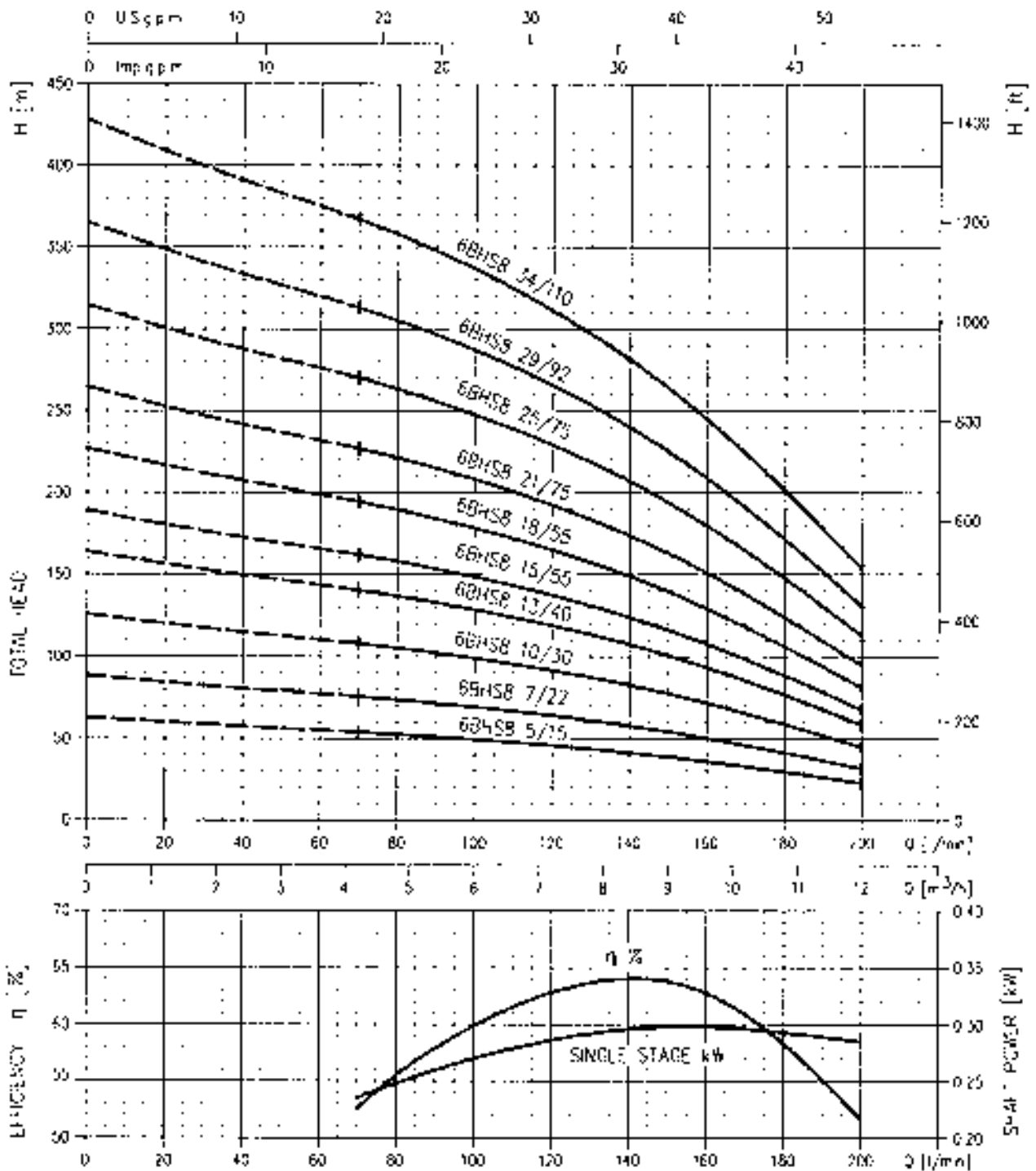

PERFORMANCE CURVES 6BHS14 series (according to ISO 9906 grade 2)

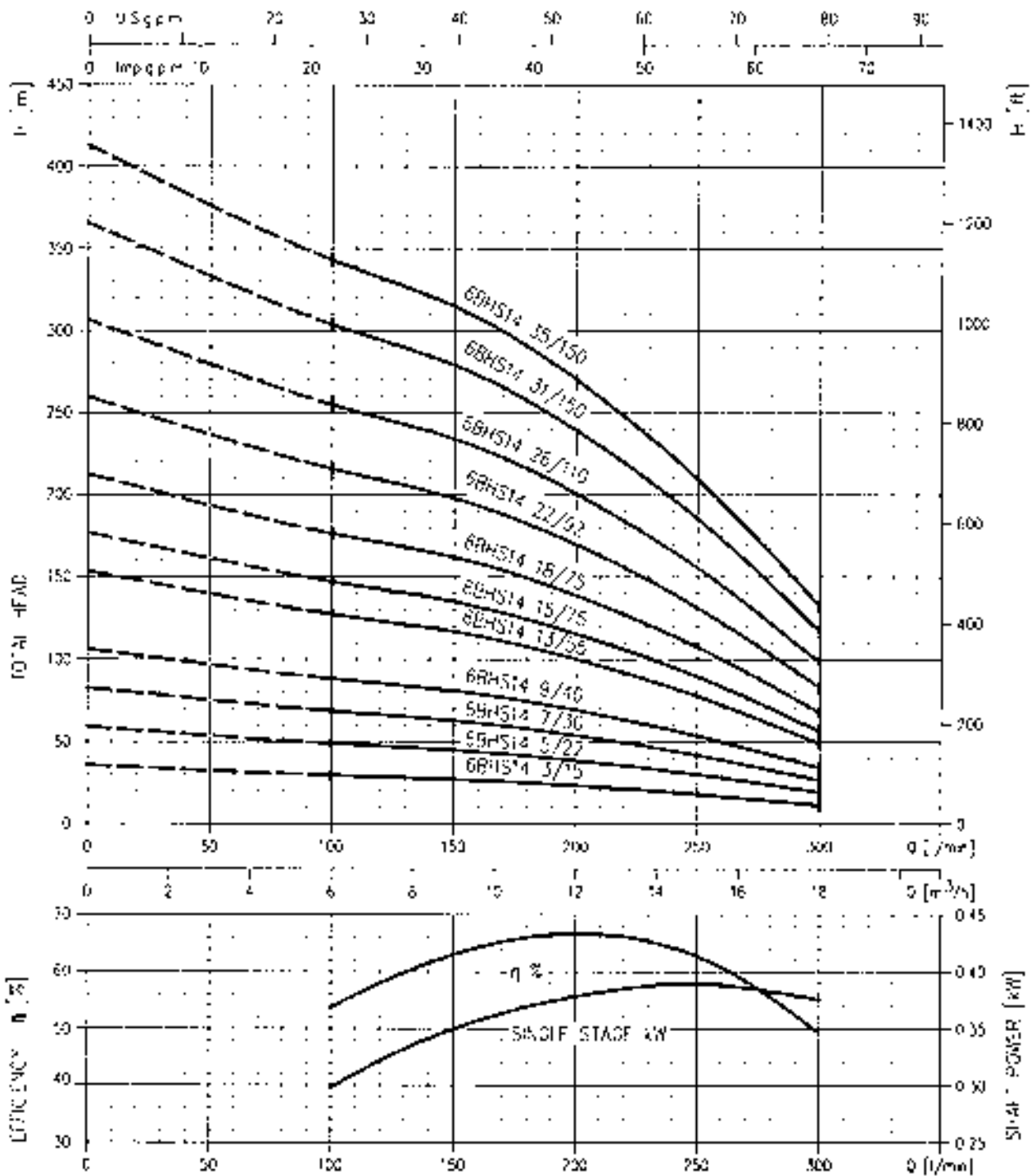

PERFORMANCE CURVES 6BHS21 series (according to ISO 9906 grade 2)

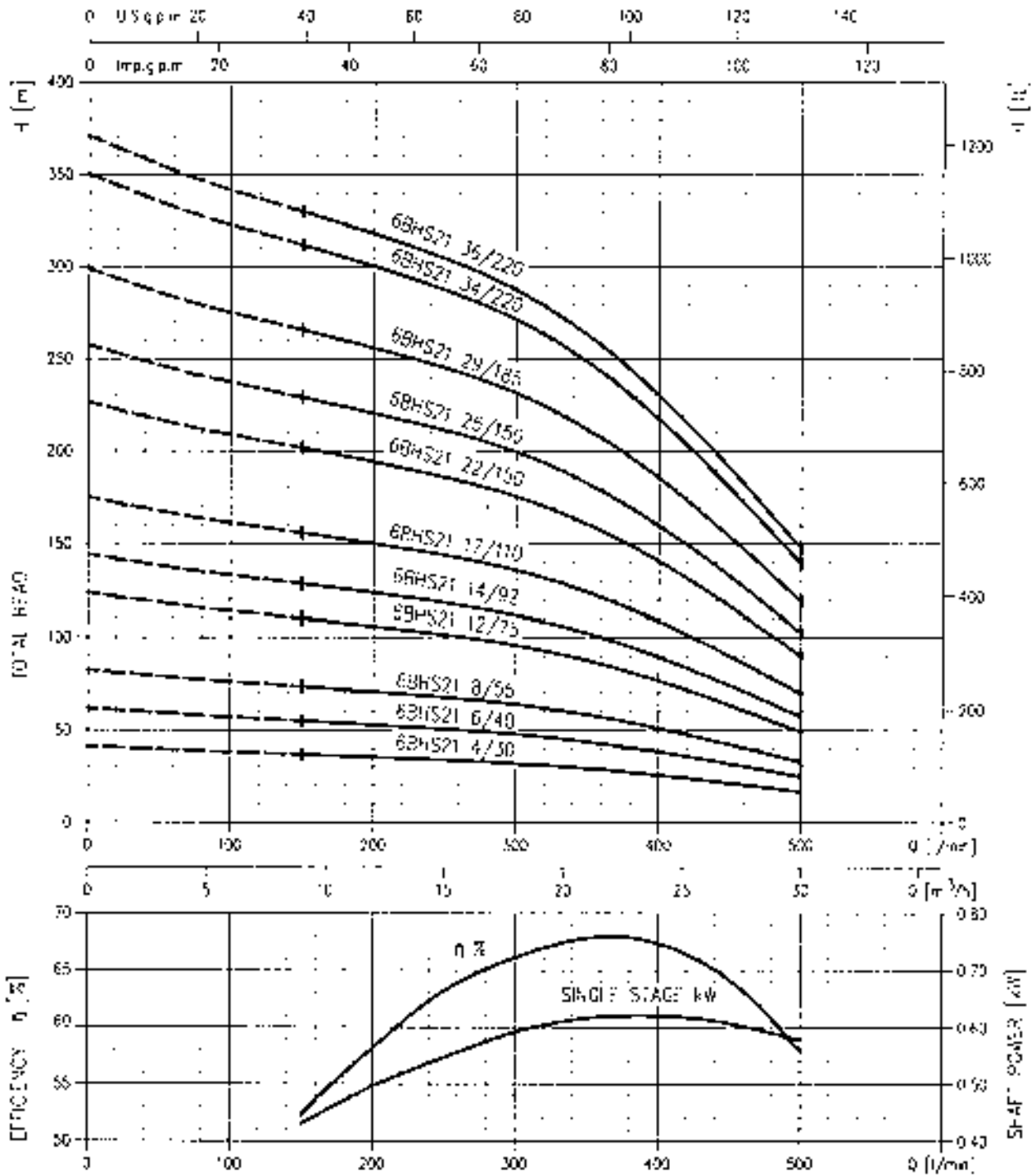

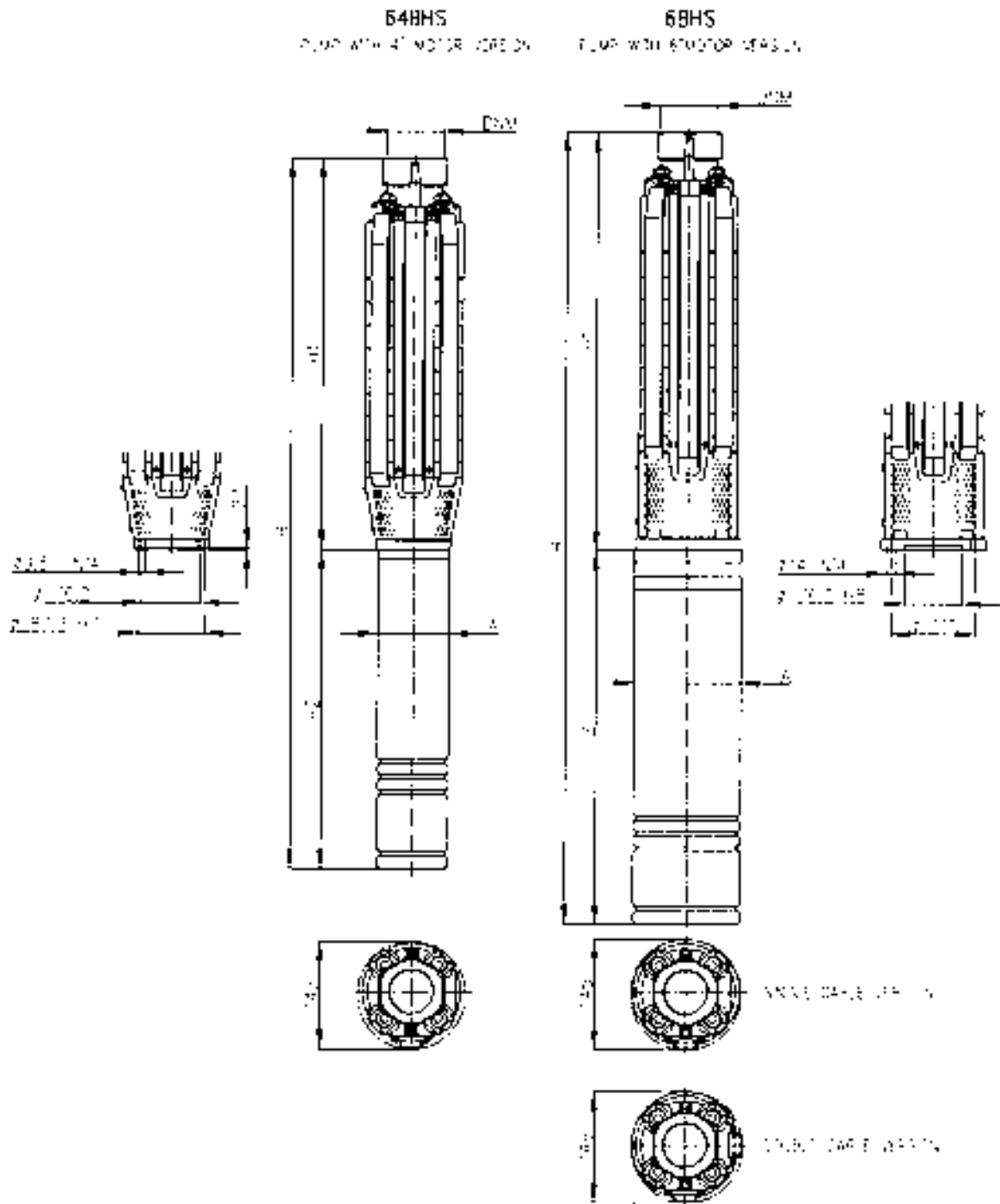

DIMENSIONAL TABLE

Pump type	Power		Pump without motor			Motor size	Pump with water motor filled		Pump with oil motor filled	
	kW	HP	DNM	H1	Weight [kgf]		H	Weight [kgf]	H	Weight [kgf]
64BHS8-5/15	1,5	2	G 2	454,5	12,5	4 "	779	24,5	837	23
64BHS8-7/22	2,2	3	G 2	514,5	14,5		868	27,5	932	26,5
64BHS8-10/30	3	4	G 2	604,5	17		1025	34	1182	39,5
64BHS8-13/40	4	5,5	G 2	694,5	20		1275	43,7	1272	42,5
64BHS8-15/55	5,5	7,5	G 2	754,5	21,5		1450	51	1402	45
64BHS8-18/55	5,5	7,5	G 2	844,5	24		1540	53,5	1492	47,5
6BHS8-13/40	4	5,5	G 2	729	21	6"	1311	59	1269	61
6BHS8-15/55	5,5	7,5	G 2	789	24		1404	64,5	1359	65
6BHS8-18/55	5,5	7,5	G 2	879	26,5		1494	66	1449	67,5
6BHS8-21/75	7,5	10	G 2	969	29,5		1616	73,5	1569	72
6BHS8-25/75	7,5	10	G 2	1089	33,5		1736	79	1689	77,5
6BHS8-29/92	9,2	12,5	G 2	1209	38,5		1888	85	1809	84
6BHS8-34/110	11	15	G 2	1359	45		2071	93	2059	91,5
64BHS14-3/15	1,5	2	G 2 1/2	394,5	10,5		4"	719	22,5	777
64BHS14-5/22	2,2	3	G 2 1/2	454,5	12	808		25,5	872	24,5
64BHS14-7/30	3	4	G 2 1/2	514,5	14	935		30,5	1092	35,5
64BHS14-9/40	4	5,5	G 2 1/2	574,5	15,5	1155		40	1152	39
64BHS14-13/55	5,5	7,5	G 2 1/2	694,5	19	1390		49	1342	43
6BHS14-9/40	4	5,5	G 2 1/2	609	17	6"	1191	54	1149	56,5
6BHS14-13/55	5,5	7,5	G 2 1/2	729	21		1344	62	1299	63
6BHS14-15/75	7,5	10	G 2 1/2	789	23		1436	68	1389	66,5
6BHS14-18/75	7,5	10	G 2 1/2	879	25,5		1526	70,5	1479	69
6BHS14-22/92	9,2	12,5	G 2 1/2	999	29,5		1678	76	1599	75,5
6BHS14-26/110	11	15	G 2 1/2	1119	33,5		1831	85	1819	84
6BHS14-31/150	15	20	G 2 1/2	1269	40,5		2046	96	2029	94,5
6BHS14-35/150	15	20	G 2 1/2	1389	44		2166	99	2149	97,5
64BHS21-4/30	3	4	G 2 1/2	474,5	11,5	4"	895	28,5	1052	33,5
64BHS21-6/40	4	5,5	G 2 1/2	554,5	13,5		1135	38,5	1132	37
64BHS21-8/55	5,5	7,5	G 2 1/2	634,5	15,5		1330	45,5	1282	39,5
6BHS21-6/40	4	5,5	G 2 1/2	589	15	6"	1171	52,3	1129	54,7
6BHS21-8/55	5,5	7,5	G 2 1/2	669	17		1284	58	1239	59
6BHS21-12/75	7,5	10	G 2 1/2	829	21,5		1476	67	1429	66
6BHS21-14/92	9,2	12,5	G 2 1/2	909	24		1588	72	1509	71
6BHS21-17/110	11	15	G 2 1/2	1029	26,5		1741	78	1729	77
6BHS21-22/150	15	20	G 2 1/2	1229	34,5		2006	89	1989	90
6BHS21-25/150	15	20	G 2 1/2	1349	38		2126	94	2109	93
6BHS21-29/185	18,5	25	G 2 1/2	1509	42,5		2351	104	2339	108
6BHS21-34/220	22	30	G 2 1/2	1709	48,5		2616	116	2599	119
6BHS21-36/220	22	30	G 2 1/2	1789	51		2696	118	2679	121