

End suction centrifugal pumps in accordance with EN 733 (ex DIN 24255) made of stainless steel AISI 304, applications include water boosting, heating systems, air-conditioning, washing systems and many other industrial applications.  
WRAS approved pumps are available upon request.



### SPECIFICATIONS

- Maximum working pressure: 10 bar
- Liquid temperature: from  $-20^{\circ}\text{C}$  to  $+110^{\circ}\text{C}$

### MATERIALS

- Pump body, impeller, casing cover and shaft in AISI 304
- Mechanical seal in carbon/ceramic/NBR for standard version
- Mechanical seal in carbon/ceramic/Viton for H version
- Mechanical seal on SiC/SiC/FPM for HS version

### TECHNICAL DATA

- Asynchronous 2 and 4 poles motor
- Insulation class F
- Protection degree IP55
- 3~230/400V  $\pm 10\%$  50Hz upto 4kW included, 400/690V  $\pm 10\%$  above
- Thermal protection to be provided by the user

Available in 5 different versions, 2 and 4 poles



monobloc with extended motor shaft



monobloc with standard motor and flexible coupling

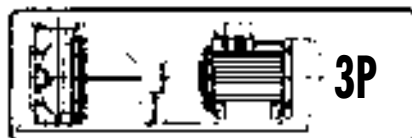

on basement with standard motor and flexible coupling

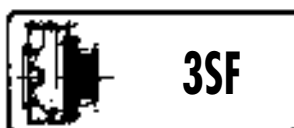
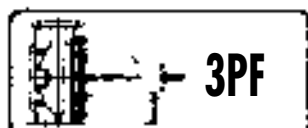

bareshaft pump

### PERFORMANCE CHART at 2900 min<sup>-1</sup> (according to ISO 9906 grade 2)

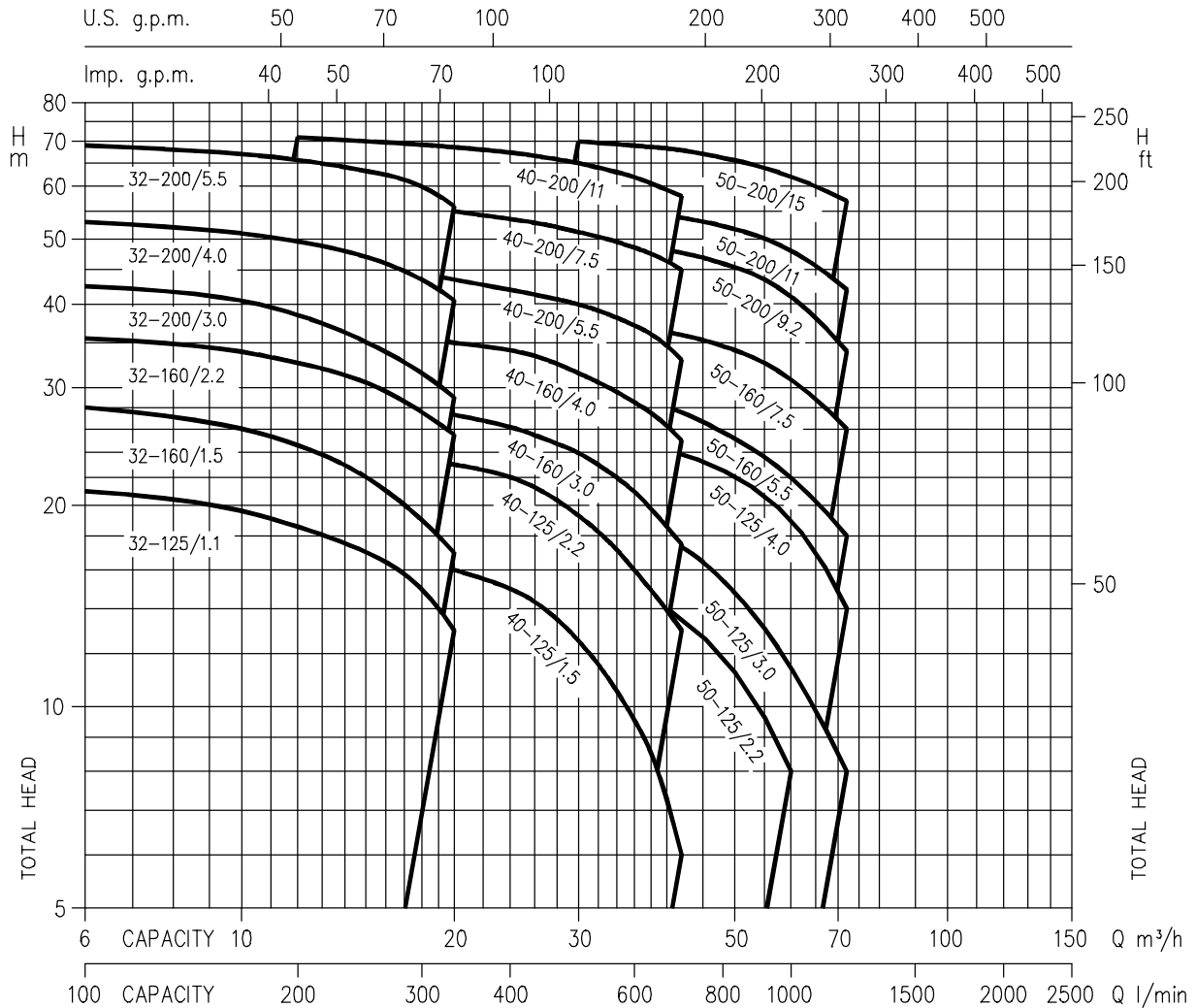

### PERFORMANCE TABLE

Pump type 3M	kW	Absorbed Current (A)			Q=Capacity	H=Total head															
		230V	Three-phase 400V	690V		100	150	200	250	300	333	400	450	500	550	600	650	700	800	1000	1200
					l/min m³/h	6	9	12	15	18	20	24	27	30	33	36	39	42	48	60	72
32-125/1.1	1.1	5.0	2.9	-	21	20	18.5	17	15	13	-	-	-	-	-	-	-	-	-	-	-
32-160/1.5	1.5	5.9	3.4	-	28	26.5	24.5	22	19	17	-	-	-	-	-	-	-	-	-	-	-
32-160/2.2	2.2	8.3	4.8	-	35.5	34.5	32.5	30.5	27.5	25.5	-	-	-	-	-	-	-	-	-	-	-
32-200/3.0	3.0	11.8	6.8	-	42.5	41	38.5	35	31.5	29	-	-	-	-	-	-	-	-	-	-	-
32-200/4.0	4.0	15.6	9.0	-	53	51.5	49.5	47	43.5	40.5	-	-	-	-	-	-	-	-	-	-	-
32-200/5.5	5.5	-	11.8	6.8	69	67.6	65.5	63	60	56	-	-	-	-	-	-	-	-	-	-	-
40-125/1.5	1.5	5.9	3.4	-	-	-	18	17.5	17	16	15	14	12.5	11	9.5	8	6	-	-	-	-
40-125/2.2	2.2	8.3	4.8	-	-	-	26	25	24.2	23	22	21	19	17.5	16	14.3	13	-	-	-	-
40-160/3.0	3.0	11.8	6.8	-	-	-	30	29	28.5	27.3	26.2	25.4	24	22.5	21	19.2	17.5	-	-	-	-
40-160/4.0	4.0	15.9	9.2	-	-	-	38	37	36	35	34	33	31.3	30	28.5	27	25	-	-	-	-
40-200/5.5	5.5	-	11.1	6.4	-	-	46	45	44	43.5	42	41	40	38.5	37	35.1	33	-	-	-	-
40-200/7.5	7.5	-	15.1	8.7	-	-	56.5	56	55.3	55	53.5	52.5	51.2	49.8	48.5	47	45	-	-	-	-
40-200/11	11	-	20.0	11.6	-	-	71	70	69.3	68.8	67.5	66.2	65	63.5	62	60	58	-	-	-	-
50-125/2.2	2.2	8.3	4.8	-	-	-	-	-	-	-	17	16.6	16.1	15.5	14.9	14.2	13.4	11.8	8	-	-
50-125/3.0	3.0	11.8	6.8	-	-	-	-	-	-	-	20.5	20	19.5	19	18.5	18	17.3	15.5	12.3	8	-
50-125/4.0	4.0	15.9	9.2	-	-	-	-	-	-	-	26	25.9	25.7	25.3	24.7	24.2	23.3	22.2	19	14	-
50-160/5.5	5.5	-	11.5	6.6	-	-	-	-	-	-	31	30.5	30	29.5	29	28	27.6	26	22.5	18	-
50-160/7.5	7.5	-	15.5	9.0	-	-	-	-	-	-	39	38.5	38	37.5	37	36.5	36	34.5	31	26	-
50-200/9.2	9.2	-	17.4	10.0	-	-	-	-	-	-	-	-	50	49.5	49	48.4	47.5	46	41	34	-
50-200/11	11	-	22.0	12.7	-	-	-	-	-	-	-	-	56	55.5	55	54.5	53.8	52	48	42	-
50-200/15	15	-	31.3	18.0	-	-	-	-	-	-	-	-	70	69.5	69	68.5	68	66	62	57	-

### PERFORMANCE CHART at 1450 min<sup>-1</sup> (according to ISO 9906 grade 2)

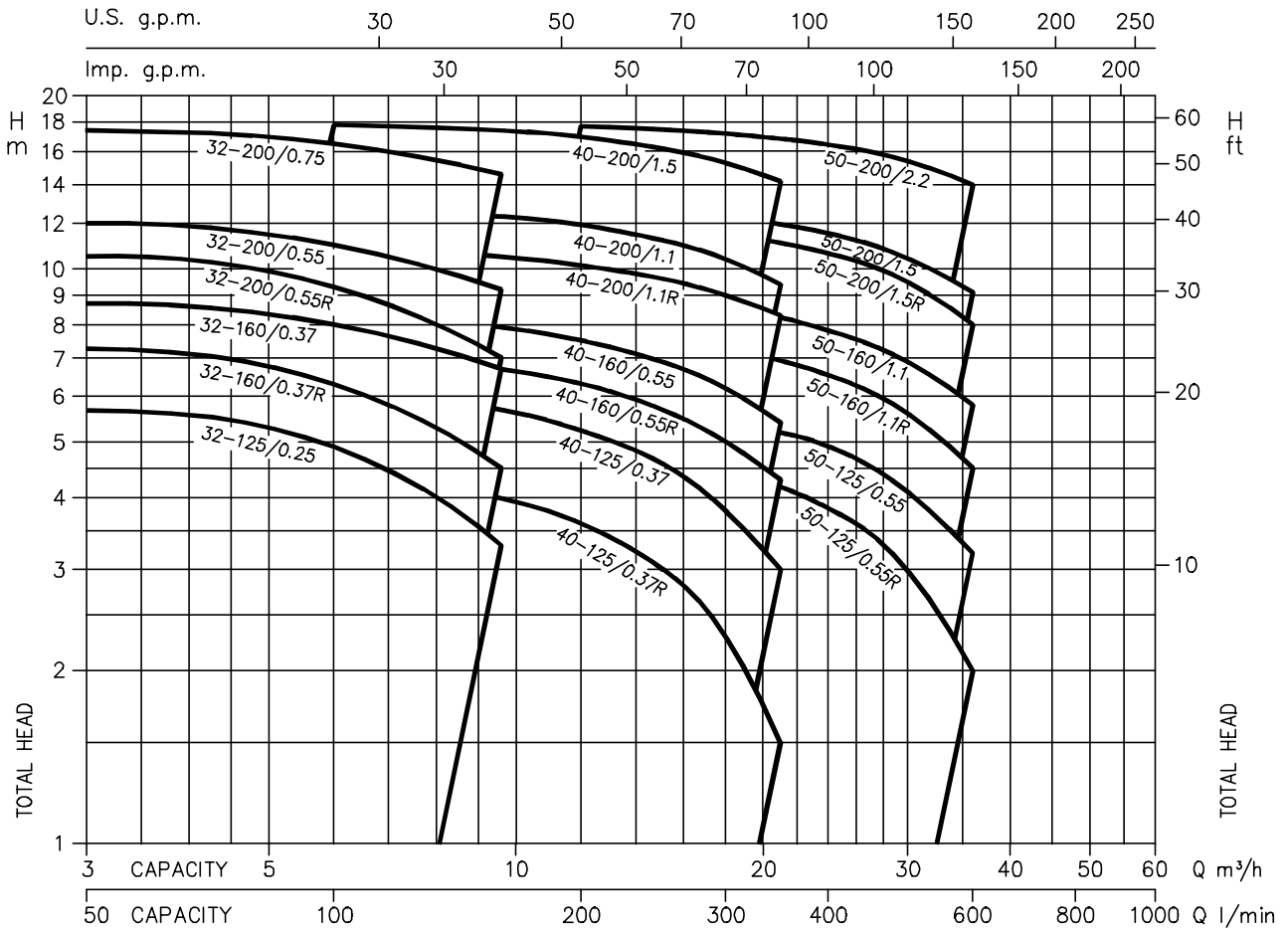

### PERFORMANCE TABLE

Pump type 3M4	kW	Absorbed Current (A)		l/min m <sup>3</sup> /h	Q=Capacity									
		Three-phase			50	100	160	200	250	300	350	400	500	600
		230V	400V		3	6	9,6	12	15	18	21	24	30	36
					H=Total head									
32-125/0.25	0,25	1,4	0,8	5,6	4,9	3,3	-	-	-	-	-	-	-	-
32-160/0.37R	0,37	1,4	0,8	7,2	6,3	4,5	-	-	-	-	-	-	-	-
32-160/0.37	0,37	1,6	0,9	8,7	8	6,7	-	-	-	-	-	-	-	-
32-200/0.55R	0,55	1,9	1,1	10,5	9,3	7	-	-	-	-	-	-	-	-
32-200/0.55	0,55	2,1	1,2	12	11	9,2	-	-	-	-	-	-	-	-
32-200/0.75	0,75	3,1	1,8	17,3	16,5	14,6	-	-	-	-	-	-	-	-
40-125/0.37R	0,37	1,5	0,9	-	4,5	4	3,6	3	2,3	1,5	-	-	-	-
40-125/0.37	0,37	1,6	0,9	-	6,2	5,7	5,2	4,6	3,8	3	-	-	-	-
40-160/0.55R	0,55	1,9	1,1	-	7,2	6,7	6,3	5,7	5	4,3	-	-	-	-
40-160/0.55	0,55	2,1	1,2	-	8,5	7,9	7,5	6,9	6,2	5,4	-	-	-	-
40-200/1.1R	1,1	3,5	2,0	-	11	10,5	10,1	9,6	9	8,3	-	-	-	-
40-200/1.1	1,1	3,8	2,2	-	12,7	12,3	11,9	11,2	10,4	9,4	-	-	-	-
40-200/1.5	1,5	6,4	3,7	-	17,8	17,4	16,9	16,2	15,3	14,2	-	-	-	-
50-125/0.55R	0,55	1,7	1,0	-	-	-	4,9	4,7	4,4	4,2	3,8	3	2	-
50-125/0.55	0,55	2,1	1,2	-	-	-	5,8	5,6	5,4	5,2	4,9	4,1	3,2	-
50-160/1.1R	1,1	3,5	2,0	-	-	-	7,7	7,5	7,2	6,9	6,5	5,6	4,5	-
50-160/1.1	1,1	3,8	2,2	-	-	-	9	8,8	8,5	8,2	7,8	6,9	5,8	-
50-200/1.5R	1,5	5,2	3,0	-	-	-	12,1	11,8	11,5	11,1	10,6	9,5	8	-
50-200/1.5	1,5	5,5	3,2	-	-	-	13	12,7	12,3	11,9	11,5	10,5	9,1	-
50-200/2.2	2,2	8,7	5,0	-	-	-	17,7	17,5	17,2	16,8	16,4	15,4	14	-

### PERFORMANCE CURVES 3M-3S-3P 32 at 2900 min<sup>-1</sup> (according to ISO 9906 grade 2)

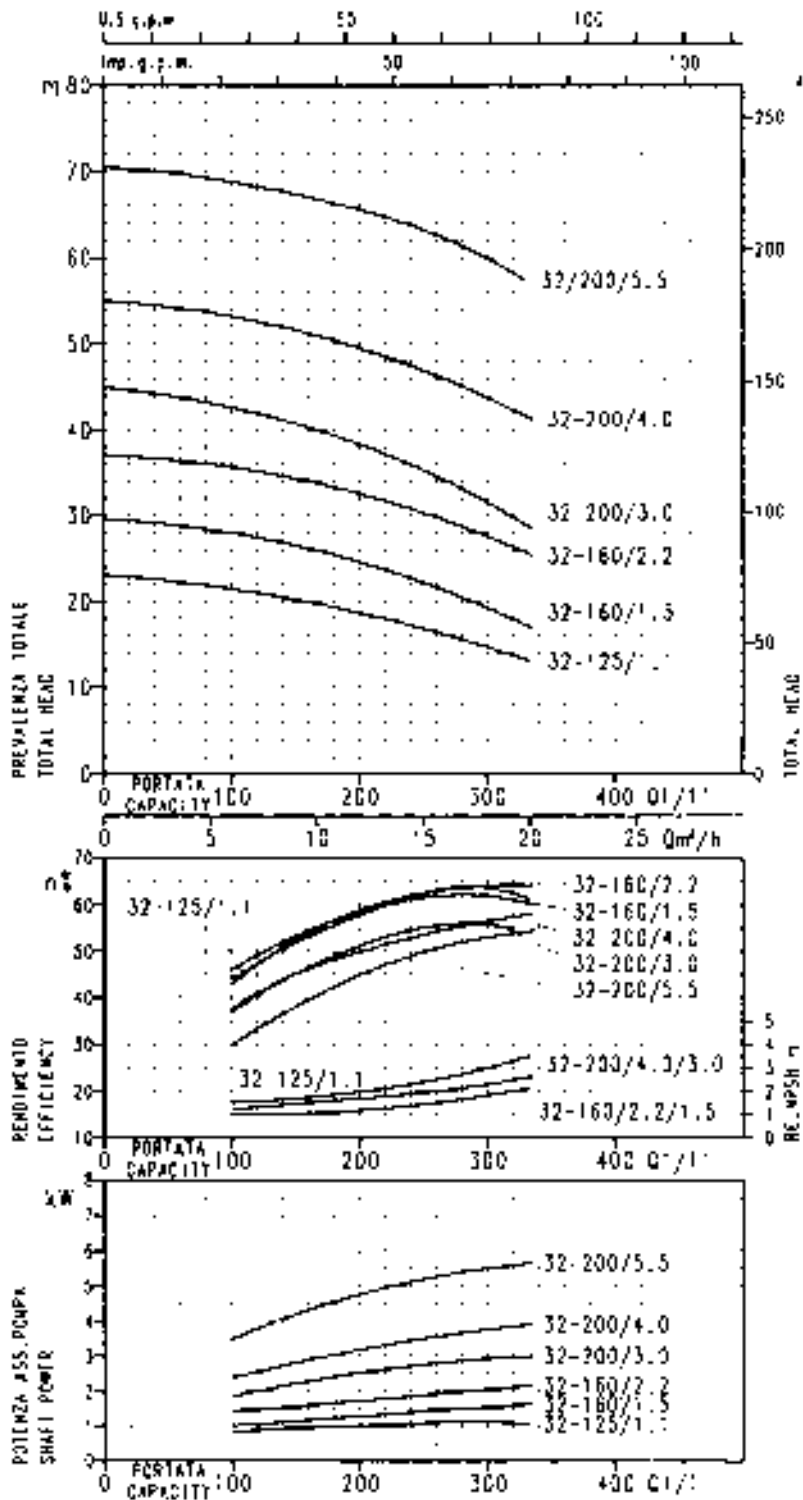

### PERFORMANCE CURVES 3M-3S-3P 40 at 2900 min<sup>-1</sup> (according to ISO 9906 grade 2)

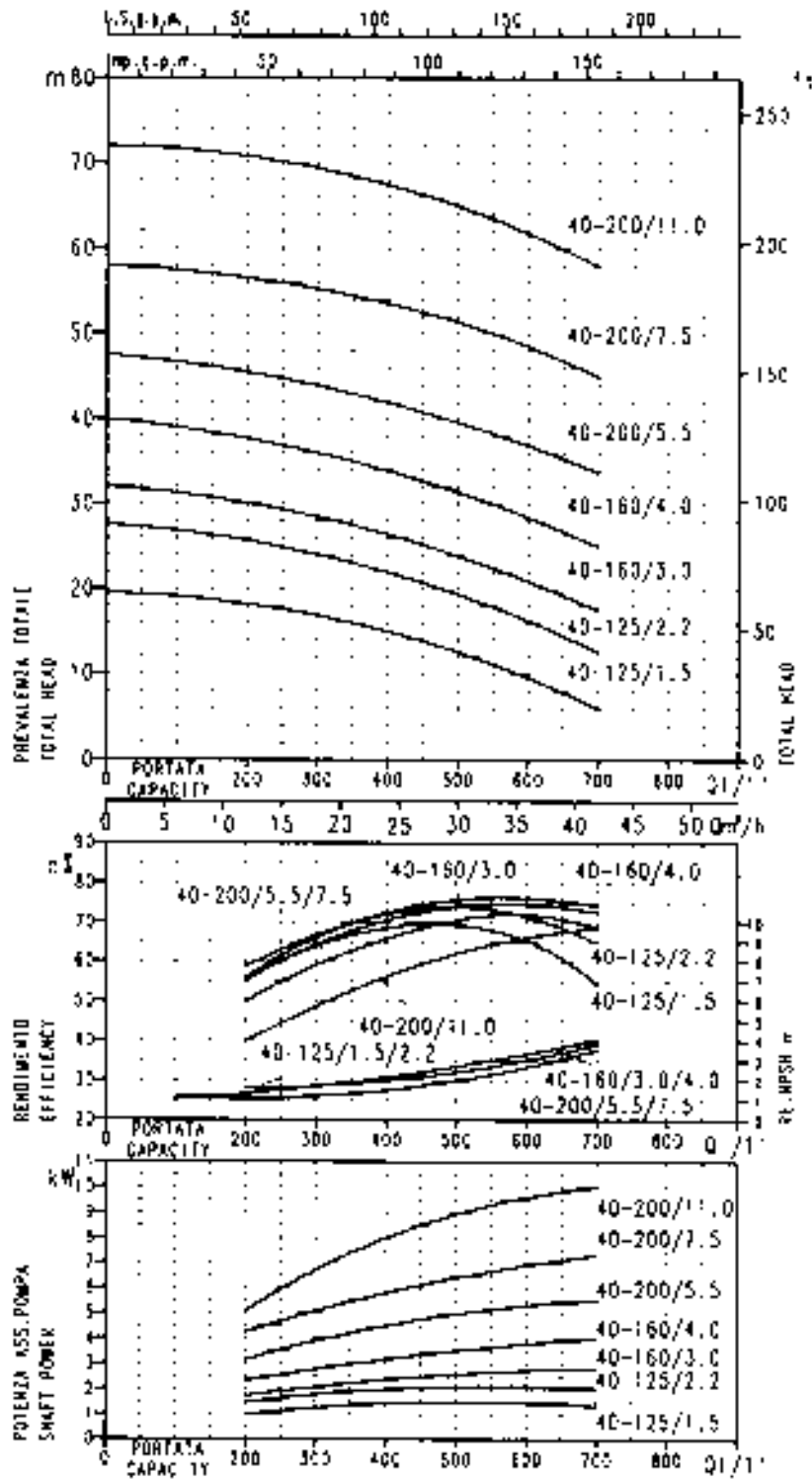

### PERFORMANCE CURVES 3M-3S-3P 50 at 2900 min<sup>-1</sup> (according to ISO 9906 grade 2)

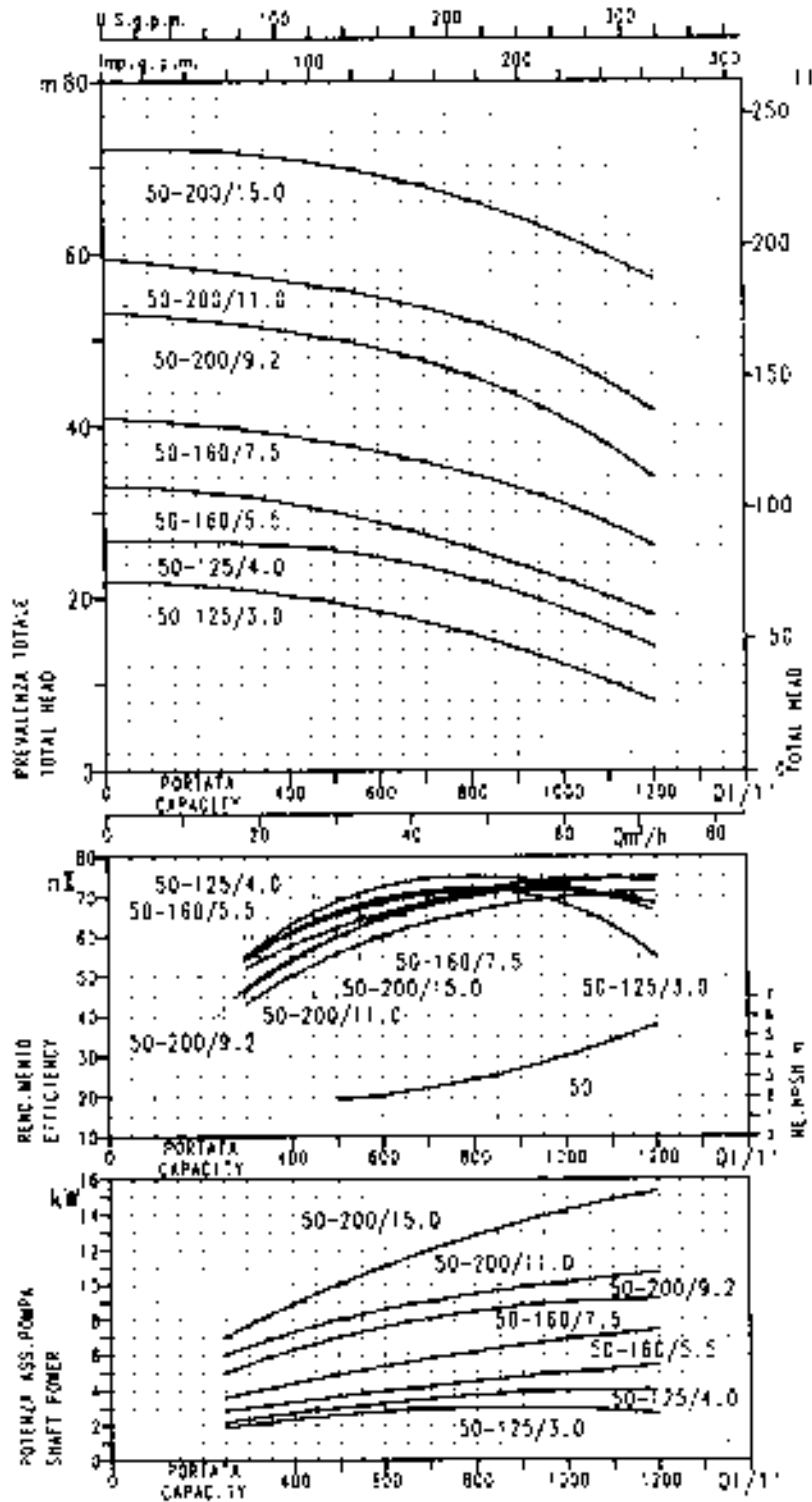

### PERFORMANCE CURVES 3M-3S-3P 32 at 1450 min<sup>-1</sup> (according to ISO 9906 grade 2)

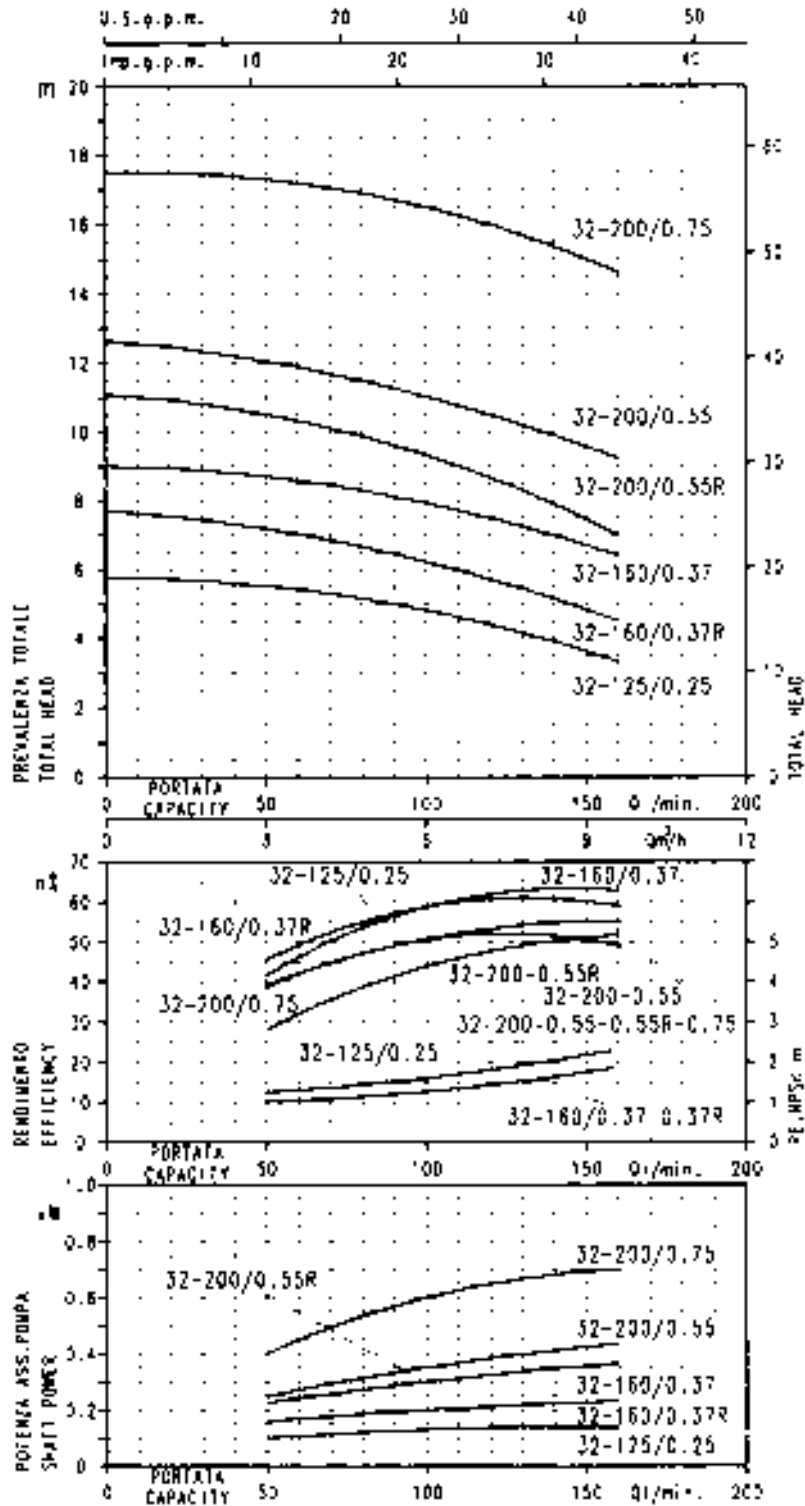

### PERFORMANCE CURVES 3M-3S-3P 40 at 1450 min<sup>-1</sup> (according to ISO 9906 grade 2)

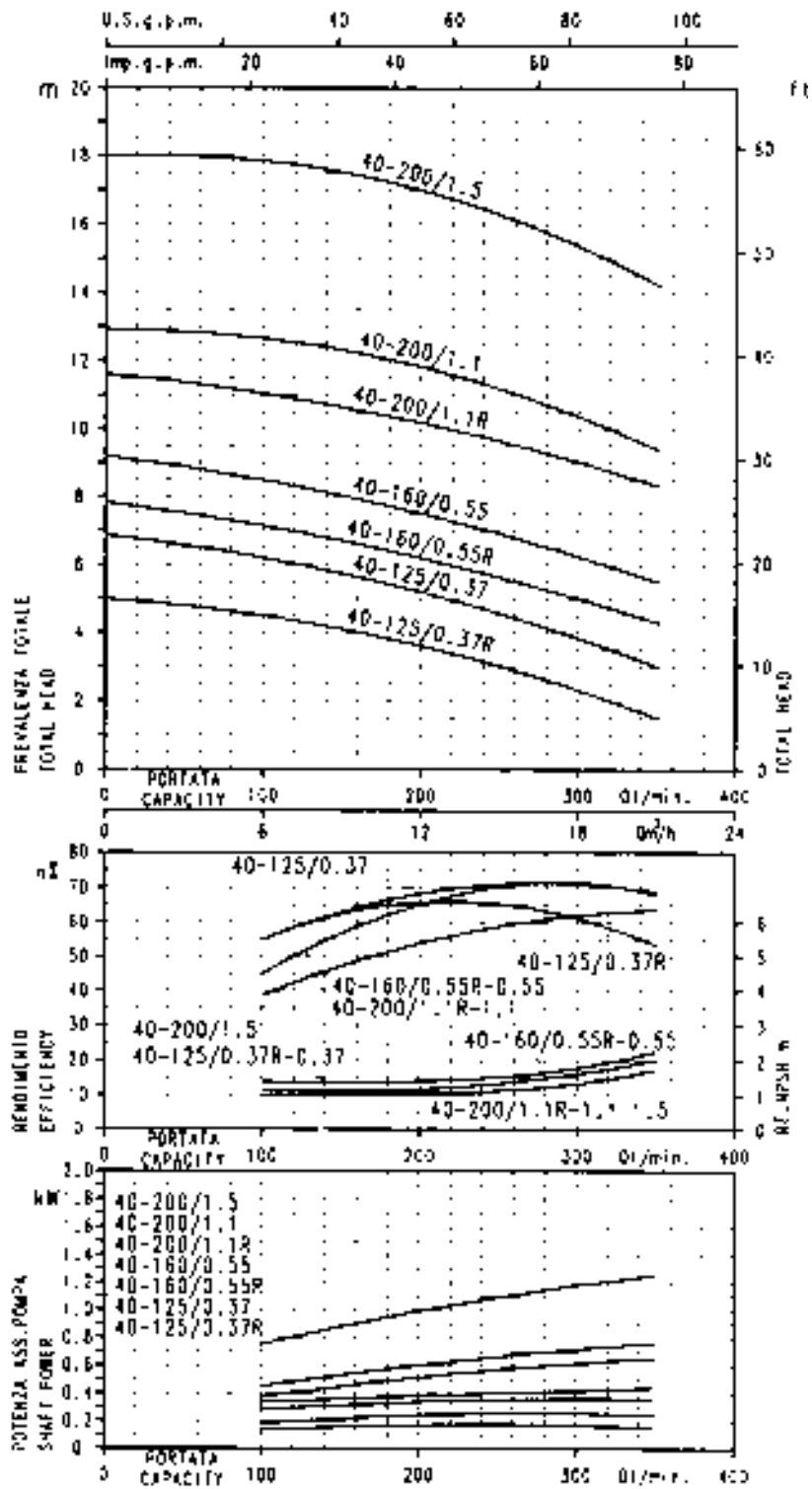

### PERFORMANCE CURVES 3M-3S-3P 50 at 1450 min<sup>-1</sup> (according to ISO 9906 grade 2)

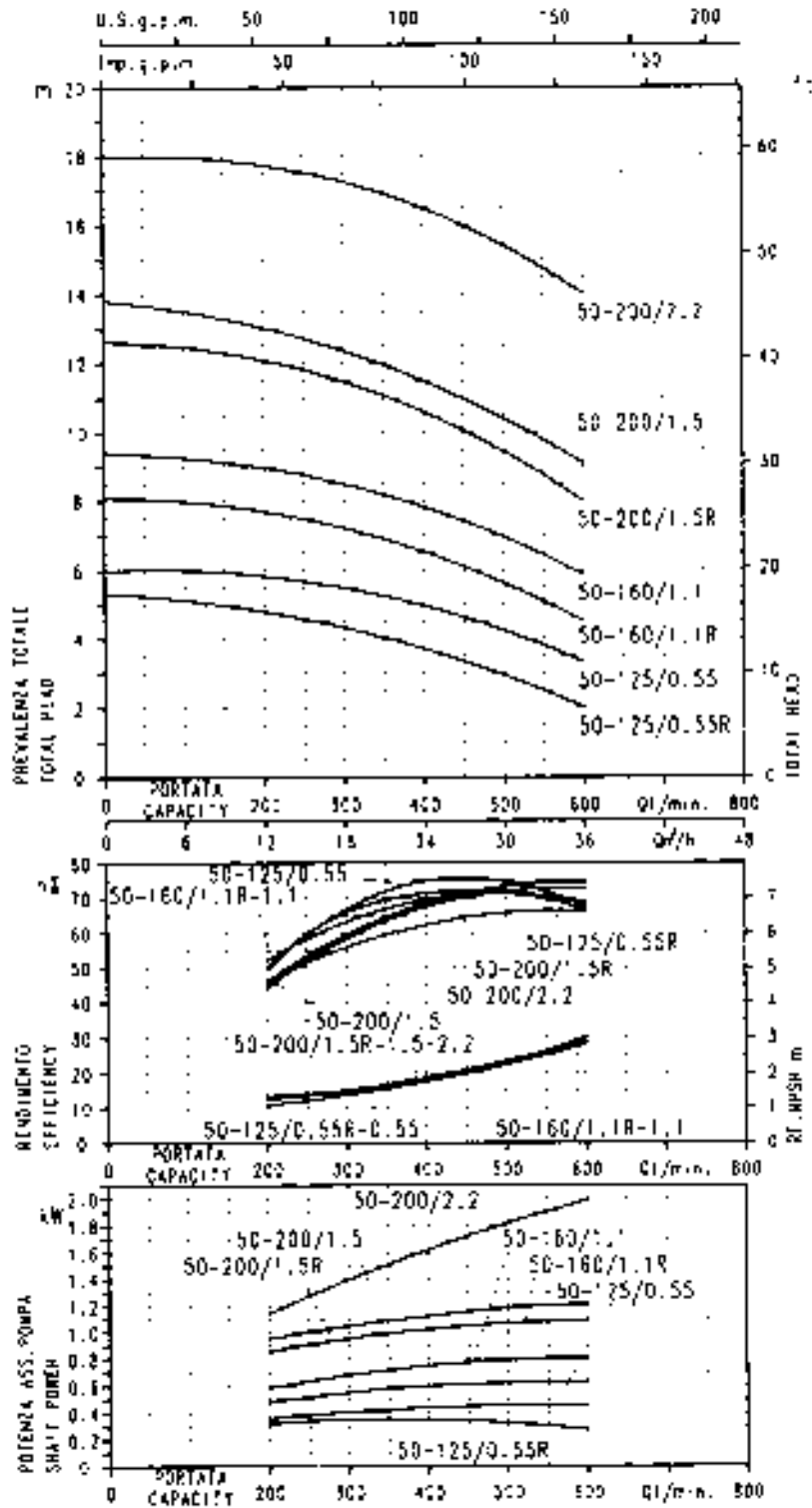



### 3M4

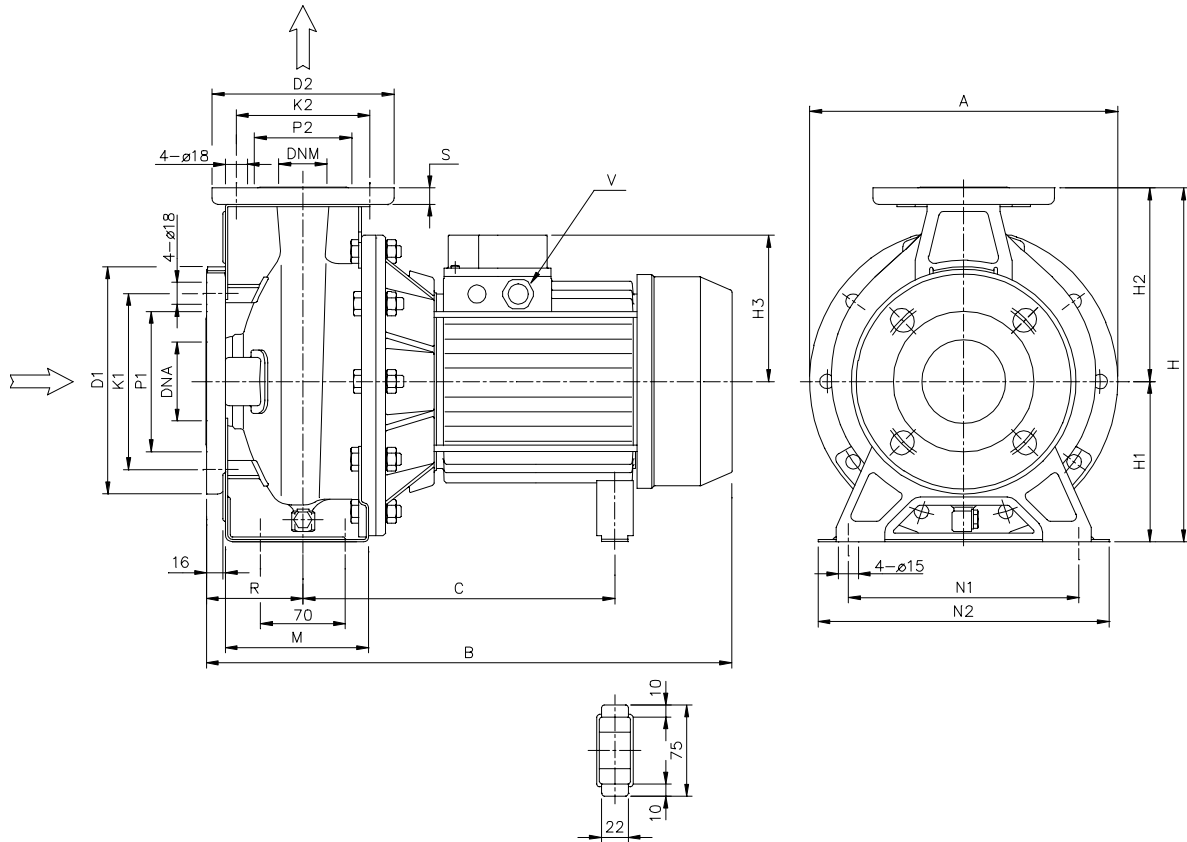

### DIMENSIONAL TABLE

Pump type 3M4	Dimensions (mm)																				Weight kg	
	A	B	C	H	H1	H2	H3	M	N1	N2	R	V	S	ØD1	ØK1	ØP1	ØD2	ØK2	ØP2	ØDNA		ØDNM
32-125/0.25	213	375	205	252	112	140	104	114	140	190	80	G3/8	14	165	125	96	140	100	76	50	32	15.0
32-160/0.37R	254	395	222	292	132	160	117	118	190	240	80	G3/8	14	165	125	96	140	100	76	50	32	20.0
32-160/0.37	254	395	222	292	132	160	117	118	190	240	80	G3/8	14	165	125	96	140	100	76	50	32	20.0
32-200/0.55R	294	395	223	340	160	180	117	119	190	240	80	G3/8	14	165	125	96	140	100	76	50	32	25.0
32-200/0.55	294	395	223	340	160	180	117	119	190	240	80	G3/8	14	165	125	96	140	100	76	50	32	25.0
32-200/0.75	294	408	232	340	160	180	122	119	190	240	80	G3/8	14	165	125	96	140	100	76	50	32	29.3
40-125/0.37R	213	375	205	252	112	140	104	114	160	210	80	G3/8	14	185	145	116	150	110	81	65	40	15.0
40-125/0.37	213	375	205	252	112	140	104	114	160	210	80	G3/8	14	185	145	116	150	110	81	65	40	15.0
40-160/0.55R	254	395	222	292	132	160	117	118	190	240	80	G3/8	14	185	145	116	150	110	81	65	40	20.0
40-160/0.55	254	395	222	292	132	160	117	118	190	240	80	G3/8	14	185	145	116	150	110	81	65	40	20.0
40-200/1.1R	294	428	232	340	160	180	122	115	212	265	100	G3/8	14	185	145	116	150	110	81	65	40	30.0
40-200/1.1	294	428	232	340	160	180	122	115	212	265	100	G3/8	14	185	145	116	150	110	81	65	40	30.0
40-200/1.5	294	428	232	340	160	180	122	115	212	265	100	G3/8	14	185	145	116	150	110	81	65	40	32.2
50-125/0.55R	254	415	222	292	132	160	117	114	190	240	100	G3/8	16	185	145	116	165	125	96	65	50	20.0
50-125/0.55	254	415	222	292	132	160	117	114	190	240	100	G3/8	16	185	145	116	165	125	96	65	50	20.0
50-160/1.1R	296	428	232	340	160	180	122	115	212	265	100	G3/8	16	185	145	116	165	125	96	65	50	30.0
50-160/1.1	296	428	232	340	160	180	122	115	212	265	100	G3/8	16	185	145	116	165	125	96	65	50	30.0
50-200/1.5R	296	428	232	360	160	200	122	115	212	265	100	G3/8	16	185	145	116	165	125	96	65	50	30.0
50-200/1.5	296	428	232	360	160	200	122	115	212	265	100	G3/8	16	185	145	116	165	125	96	65	50	30.0
50-200/2.2	296	478	256	360	160	200	134	115	212	265	100	G1/2	16	185	145	116	165	125	96	65	50	31.8

### 3S

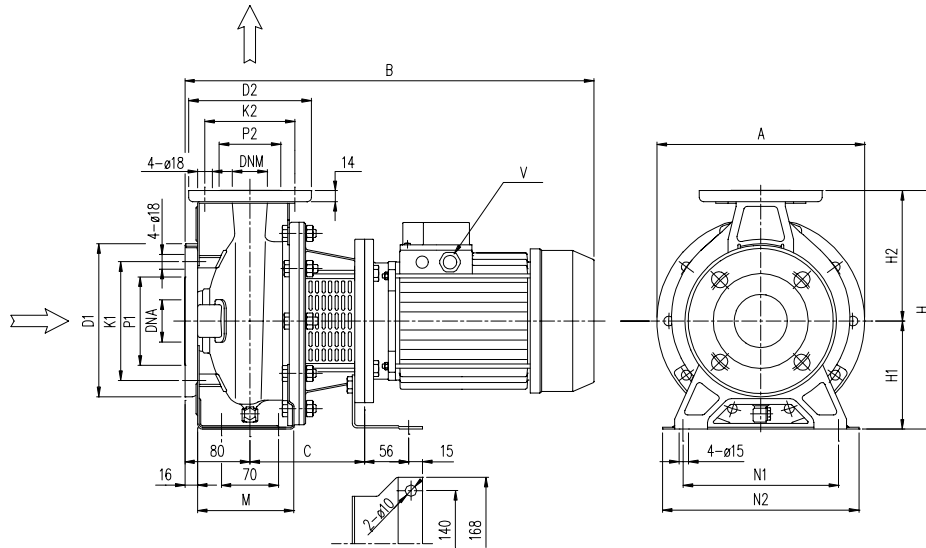

#### DIMENSIONAL TABLE

Pump type 3S	Dimensions (mm)																		Weight kg
	A	B	C	H	H1	H2	M	N1	N2	V	ØD1	ØK1	ØP1	ØD2	ØK2	ØP2	ØDNA	ØDNM	
32-125/1.1	213	435	118	252	112	140	114	140	190	PG16	165	125	96	140	100	76	50	32	22,0
32-160/1.5	254	467	130	292	132	160	118	190	240	PG16	165	125	96	140	100	76	50	32	28,0
32-160/2.2	254	492	130	292	132	160	118	190	240	PG16	165	125	96	140	100	76	50	32	31,0
40-125/1.5	213	467	130	292	112	140	114	160	210	PG16	185	145	116	150	110	81	65	40	26,5
40-125/2.2	213	492	130	292	112	140	114	160	210	PG16	185	145	116	150	110	81	65	40	23,5

### 3S

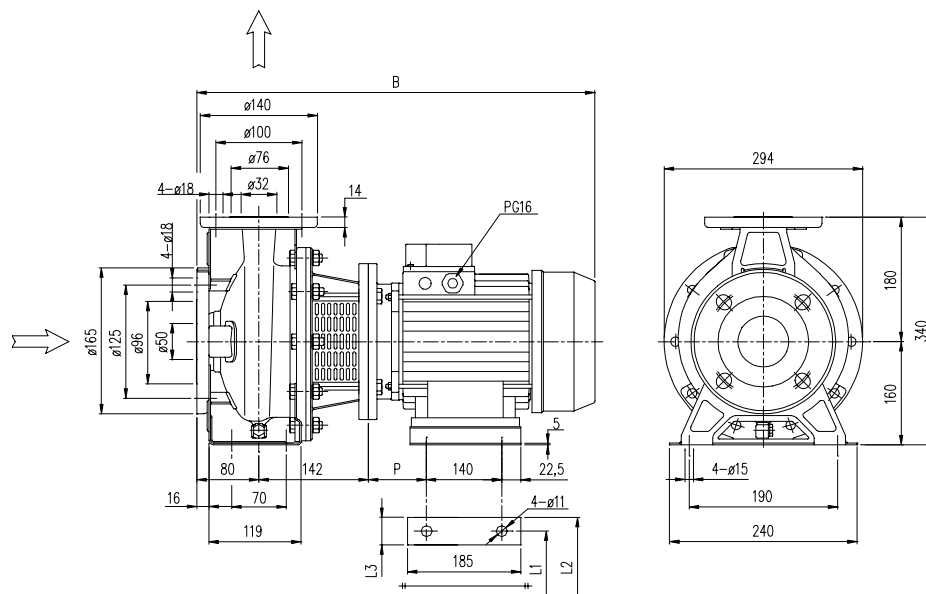

Pump type 3S	Dimensions (mm)					Weight kg
	B	L1	L2	L3	P	
32-200/3.0	535	160	202	43	63	44,4
32-200/4.0	556	190	228	38	70	48,4



### 3S4

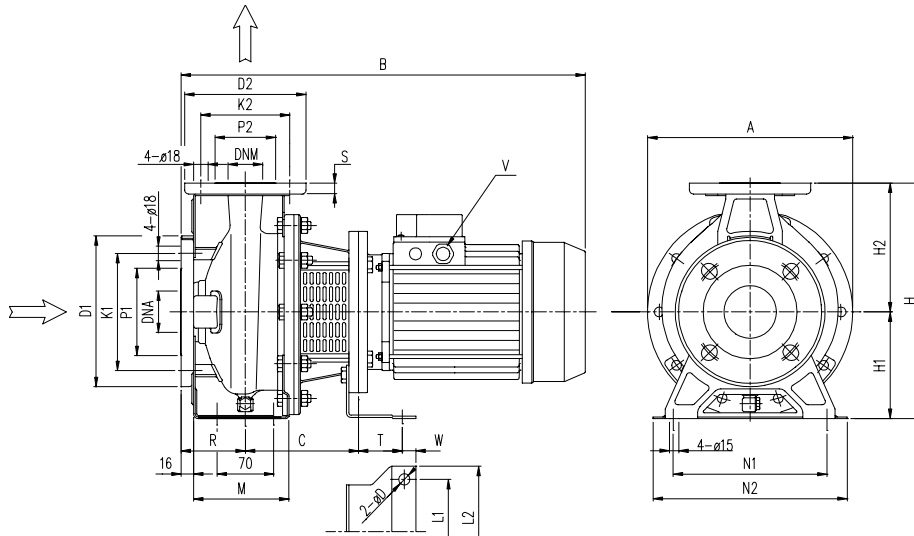

### DIMENSIONAL TABLE

Pump type 3S4	Dimensions (mm)																				Weight kg					
	A	B	C	D	H	H1	H2	L1	L2	M	N1	N2	R	S	T	V	W	ØD1	ØK1	ØP1		ØD2	ØK2	ØP2	ØDNA	ØDNM
32-125/0.25	213	401	108	8	252	112	140	112	140	114	140	190	80	14	45	PG13,5	15	165	125	96	140	100	76	50	32	15,5
32-160/0.37R	254	401	108	8	292	132	160	112	140	118	190	240	80	14	45	PG13,5	15	165	125	96	140	100	76	50	32	20,7
32-160/0.37	254	401	108	8	292	132	160	112	140	118	190	240	80	14	45	PG13,5	15	165	125	96	140	100	76	50	32	20,7
32-200/0.55R	296	435	118	10	340	160	180	140	168	119	190	240	80	14	56	PG13,5	15	165	125	96	140	100	76	50	32	28,9
32-200/0.55	296	435	118	10	340	160	180	140	168	119	190	240	80	14	56	PG13,5	15	165	125	96	140	100	76	50	32	28,9
32-200/0.75	296	435	118	10	252	160	180	140	168	119	190	240	80	14	56	PG13,5	15	165	125	96	140	100	76	50	32	30,1
40-125/0.37R	213	401	118	8	252	112	180	112	140	114	160	210	80	14	45	PG13,5	15	185	145	116	150	110	81	65	40	17,6
40-125/0.37	213	401	118	8	292	112	140	112	140	114	160	210	80	14	45	PG13,5	15	185	145	116	150	110	81	65	40	17,6
40-160/0.55R	254	435	118	10	292	132	140	140	168	118	190	210	80	14	56	PG13,5	15	185	145	116	150	110	81	65	40	23,2
40-160/0.55	254	435	118	10	340	132	160	140	168	118	190	210	80	14	56	PG13,5	15	185	145	116	150	110	81	65	40	23,2
40-200/1.1R	294	487	130	10	340	160	180	140	168	115	212	265	100	14	56	PG16	15	185	145	116	150	110	81	65	40	33,3
40-200/1.1	294	487	130	10	340	160	180	140	168	115	212	265	100	14	56	PG16	15	185	145	116	150	110	81	65	40	33,3
40-200/1.5	294	512	130	10	292	160	180	140	168	115	212	265	100	14	56	PG16	15	185	145	116	150	110	81	65	40	35,5
50-125/0.55R	254	452	118	10	292	132	160	140	168	114	190	240	100	16	56	PG13,5	15	185	145	116	150	125	96	65	50	23,5
50-125/0.55	254	452	118	10	340	132	160	140	168	114	190	240	100	16	56	PG13,5	15	185	145	116	150	125	96	65	50	23,5
50-160/1.1R	296	487	130	10	340	160	180	140	168	115	212	265	100	16	56	PG16	15	185	145	116	150	125	96	65	50	34,0
50-160/1.1	296	487	130	10	360	160	180	140	168	115	212	265	100	16	56	PG16	15	185	145	116	150	125	96	65	50	34,0
50-200/1.5R	296	512	130	10	360	160	200	140	168	115	212	265	100	16	56	PG16	15	185	145	116	150	125	96	65	50	30,0
50-200/1.5	296	512	130	10	360	160	200	140	168	115	212	265	100	16	56	PG16	15	185	145	116	150	125	96	65	50	30,0

### 3S4 50-200/2.2

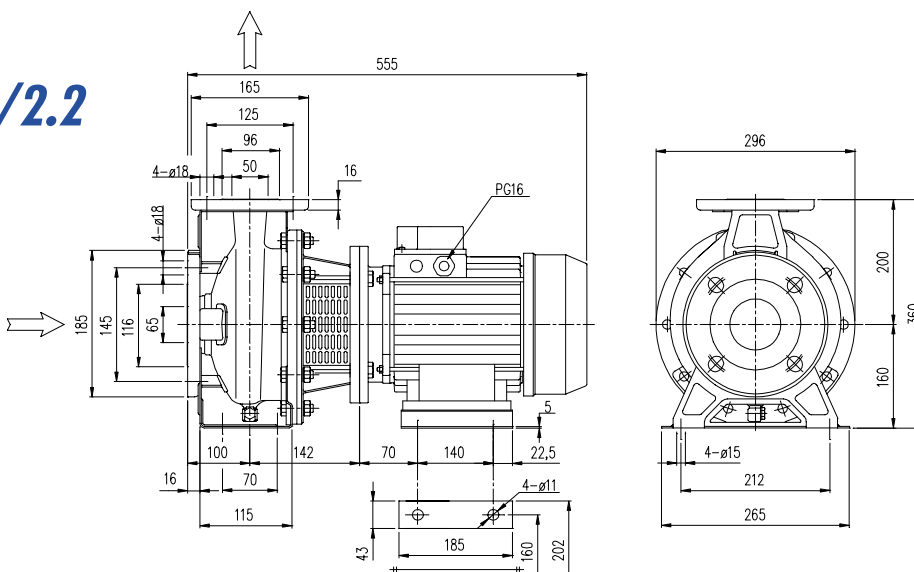

### 3P-3P4

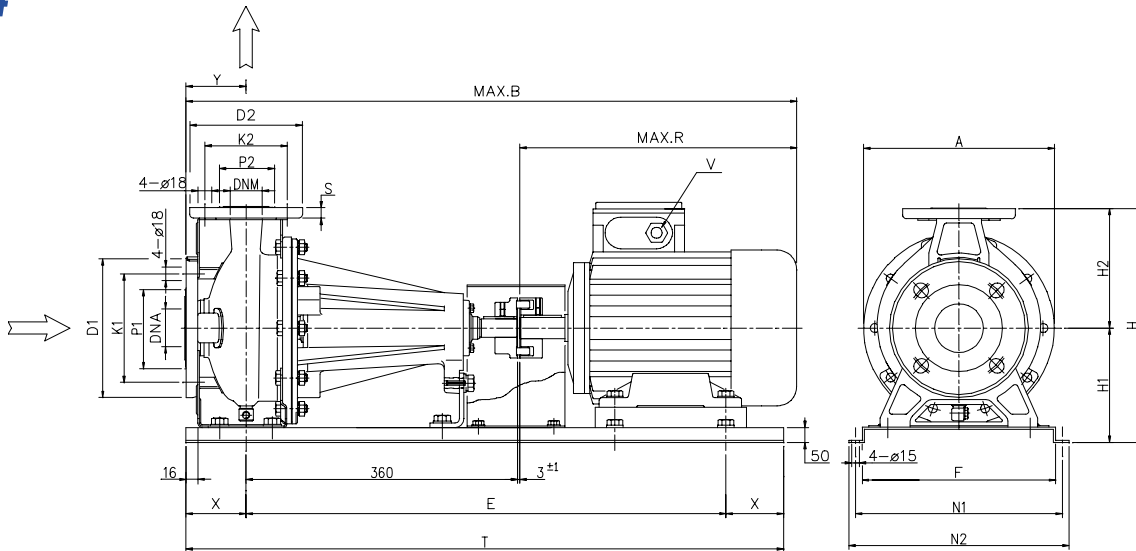

### DIMENSIONAL TABLE

Pump type 3P	Dimensions (mm)																				Weight kg				
	A	B	E	F	H	H1	H2	L	N1	N2	X	Y	R	T	S	V	ØD1	ØK1	ØP1	ØD2		ØK2	ØP2	ØDNA	ØDNM
32-125/1.1	213	713	550	250	302	162	140	440	300	340	80	80	270	710	14	PG16	165	125	95	140	100	75	50	32	43.5
32-160/1.5	254	763	590	300	342	182	160	440	350	390	80	80	320	750	14	PG16	165	125	95	140	100	75	50	32	51.0
32-160/2.2	254	763	590	300	342	182	160	440	350	390	80	80	320	750	14	PG16	165	125	95	140	100	75	50	32	53.5
32-200/3.0	296	843	590	300	390	210	180	440	350	390	80	80	400	750	14	PG16	165	125	95	140	100	75	50	32	68.0
32-200/4.0	296	843	590	300	390	210	180	440	350	390	80	80	400	750	14	PG16	165	125	95	140	100	75	50	32	72.0
32-200/5.5	296	925	650	300	390	210	180	440	350	390	100	80	482	850	14	PG21	165	125	115	150	110	80	65	40	88.0
40-125/1.5	213	763	550	250	302	162	140	440	300	340	80	80	320	710	14	PG16	185	145	115	150	110	80	65	40	48.5
40-125/2.2	213	763	550	250	302	162	140	440	300	340	80	80	320	710	14	PG16	185	145	115	150	110	80	65	40	51.0
40-160/3.0	254	843	590	300	342	182	160	440	350	390	80	80	400	750	14	PG16	185	145	115	150	110	80	65	40	77.5
40-160/4.0	254	843	590	300	342	182	160	440	350	390	80	80	400	750	14	PG16	185	145	115	150	110	80	65	40	64.5
40-200/5.5	296	945	650	300	390	210	180	460	350	390	100	100	482	850	14	PG21	185	145	115	150	110	80	65	40	89.0
40-200/7.5	296	945	650	300	390	210	180	460	350	390	100	100	482	850	14	PG21	185	145	115	150	110	80	65	40	94.5
40-200/11	296	1111	800	330	390	210	180	460	380	420	100	100	648	1000	14	PG29	185	145	115	150	110	80	65	40	117.0
50-125/3.0	254	863	590	300	342	182	160	460	350	390	80	100	400	750	16	PG16	185	145	115	165	125	95	65	50	79.0
50-125/4.0	254	863	590	300	342	182	160	460	350	390	80	100	400	750	16	PG16	185	145	115	165	125	95	65	50	81.5
50-160/5.5	296	945	650	300	390	210	180	460	350	390	100	100	482	850	16	PG21	185	145	115	165	125	95	65	50	89.0
50-160/7.5	296	945	650	300	390	210	180	460	350	390	100	100	482	850	16	PG21	185	145	115	165	125	95	65	50	94.5
50-200/9.2	296	945	650	300	410	210	200	460	350	390	100	100	482	850	16	PG21	185	145	115	165	125	95	65	50	100.0
50-200/11	296	1111	800	330	410	210	200	460	380	420	100	100	648	1000	16	PG29	185	145	115	165	125	95	65	50	117.5
50-200/15	296	1111	800	330	410	210	200	460	380	420	100	100	648	1000	16	PG29	185	145	115	165	125	95	65	50	125.4

Pump type 3P4	Dimensions (mm)																				Weight kg			
	A	B	E	F	H	H1	H2	N1	N2	X	Y	R	T	S	V	ØD1	ØK1	ØP1	ØD2	ØK2		ØP2	ØDNA	ØDNM
32-125/0.25	213	683	550	250	302	162	140	300	340	80	80	240	710	14	PG11	165	125	95	140	100	75	50	32	37.0
32-160/0.37R	254	683	510	300	342	182	160	350	390	80	80	240	670	14	PG11	165	125	95	140	100	75	50	32	41.0
32-160/0.37	254	683	510	300	342	182	160	350	390	80	80	240	670	14	PG11	165	125	95	140	100	75	50	32	41.0
32-200/0.55R	296	717	510	300	390	210	180	350	390	80	80	274	670	14	PG13.5	165	125	95	140	100	75	50	32	53.5
32-200/0.55	296	717	510	300	390	210	180	350	390	80	80	274	670	14	PG13.5	165	125	95	140	100	75	50	32	53.5
32-200/0.75	296	717	510	300	390	210	180	350	390	80	80	274	670	14	PG13.5	165	125	95	140	100	75	50	32	54.5
40-125/0.37R	213	683	550	250	302	162	140	300	340	80	80	240	710	14	PG11	185	145	115	150	110	80	65	40	46.5
40-125/0.37	213	683	550	250	302	162	140	300	340	80	80	240	710	14	PG11	185	145	115	150	110	80	65	40	46.5
40-160/0.55R	254	717	510	300	342	182	160	350	390	80	80	274	670	14	PG13.5	185	145	115	150	110	80	65	40	44.5
40-160/0.55	254	717	590	300	342	182	160	350	390	80	80	274	670	14	PG13.5	185	145	115	150	110	80	65	40	44.5
40-200/1.1R	296	795	590	300	390	210	180	350	390	80	80	332	750	14	PG16	185	145	115	150	110	80	65	40	61.5
40-200/1.1	296	795	590	300	390	210	180	350	390	80	80	332	750	14	PG16	185	145	115	150	110	80	65	40	61.5
40-200/1.5	296	795	510	300	390	210	180	350	390	80	80	332	750	14	PG16	185	145	115	150	110	80	65	40	64.0
50-125/0.55R	254	737	510	300	342	182	160	350	390	80	80	274	670	16	PG13.5	185	145	115	165	125	95	65	50	45.0
50-125/0.55	254	737	590	300	342	182	160	350	390	80	80	274	670	16	PG13.5	185	145	115	165	125	95	65	50	45.0
50-160/1.1R	296	795	590	300	390	210	180	350	390	80	80	332	750	16	PG16	185	145	115	165	125	95	65	50	52.5
50-160/1.1	296	795	590	300	390	210	180	350	390	80	80	332	750	16	PG16	185	145	115	165	125	95	65	50	52.5
50-200/1.5R	296	795	590	300	410	210	200	350	390	80	80	332	750	16	PG16	185	145	115	165	125	95	65	50	64.0
50-200/1.5	296	795	590	300	410	210	200	350	390	80	80	332	750	16	PG16	185	145	115	165	125	95	65	50	64.0
50-200/2.2	296	863	590	300	410	210	200	350	390	80	80	400	750	16	PG16	185	145	115	165	125	95	65	50	70

### 3SF-3SF4

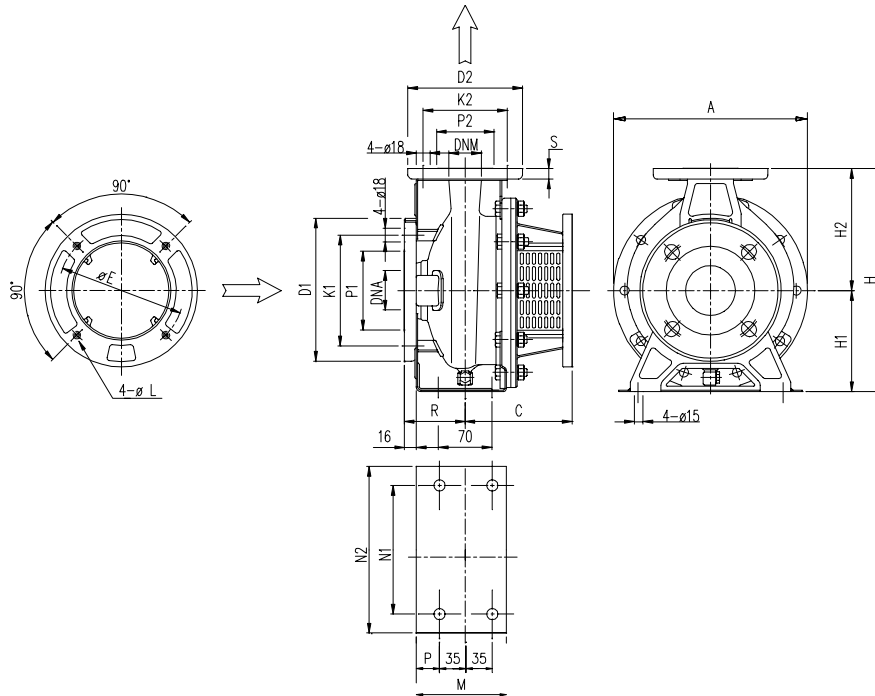

#### DIMENSIONAL TABLE

Pump type 3SF	Dimensions (mm)																				
	A	C	E	H	H1	H2	L	M	N1	N2	P	R	S	ØD1	ØK1	ØP1	ØD2	ØK2	ØP2	ØDNA	ØDNM
32-125/N	213	118	165	252	112	140	M10	114	140	190	29	80	14	165	125	96	140	100	76	50	32
32-160/R	254	130	165	292	132	160	M10	118	190	240	29	80	14	165	125	96	140	100	76	50	32
32-160/N	254	130	165	292	132	160	M10	118	190	240	29	80	14	165	125	96	140	100	76	50	32
32-200/R	294	142	215	340	160	180	M12	119	190	240	29	80	14	165	125	96	140	100	76	50	32
32-200/N	294	142	215	340	160	180	M12	119	190	240	29	80	14	165	125	96	140	100	76	50	32
32-200/L	294	165	265	340	160	180	M12	119	190	240	29	80	14	165	125	96	140	100	76	50	32
40-125/R	213	130	165	252	112	140	M10	114	160	210	29	80	14	185	145	116	150	110	81	65	40
40-125/N	213	130	165	252	112	140	M10	114	160	210	29	80	14	185	145	116	150	110	81	65	40
40-160/R	254	142	215	292	132	160	M12	118	190	240	29	80	14	185	145	116	150	110	81	65	40
40-160/N	254	142	215	292	132	160	M12	118	190	240	29	80	14	185	145	116	150	110	81	65	40
40-200/R	294	165	265	340	160	180	M12	115	212	265	25	100	14	185	145	116	150	110	81	65	40
40-200/N	294	165	265	340	160	180	M12	115	212	265	25	100	14	185	145	116	150	110	81	65	40
40-200/L	294	198	300	340	160	180	M16	115	212	265	25	100	14	185	145	116	150	110	81	65	40
50-125/R	254	142	215	292	132	160	M12	114	190	240	25	100	16	185	145	116	165	125	96	65	50
50-125/N	254	142	215	292	132	160	M12	114	190	240	25	100	16	185	145	116	165	125	96	65	50
50-160/R	296	165	265	340	160	180	M12	115	115	212	25	100	16	185	145	116	165	125	96	65	50
50-160/N	296	165	265	340	160	180	M12	115	115	212	25	100	16	185	145	116	165	125	96	65	50
50-200/R	296	165	265	360	160	200	M12	115	212	265	25	390	16	185	145	116	165	125	96	65	50
50-200/N	296	198	300	360	160	200	M16	115	212	265	25	390	16	185	145	116	165	125	96	65	50
50-200/L	296	198	300	360	160	200	M16	115	212	265	25	390	16	185	145	116	165	125	96	65	50

#### DIMENSIONAL TABLE

Pump type 3SF4	Dimensions (mm)																				Weight kg	
	A	C	E	H	H1	H2	L	M	N1	N2	P	R	S	ØD1	ØK1	ØP1	ØD2	ØK2	ØP2	ØDNA		ØDNM
32-125/N	213	108	130	252	112	140	M8	114	140	190	29	80	14	165	125	96	140	100	76	50	32	
32-160/R	254	108	130	292	132	160	M8	118	190	240	29	80	14	165	125	96	140	100	76	50	32	
32-160/N	254	108	130	292	132	160	M8	118	190	240	29	80	14	165	125	96	140	100	76	50	32	
32-200/R	296	118	165	340	160	180	M10	119	190	240	29	80	14	165	125	96	140	100	76	50	32	
32-200/N	296	118	165	340	160	180	M10	119	190	240	29	80	14	165	125	96	140	100	76	50	32	
32-200/L	296	118	165	340	160	180	M10	119	190	240	29	80	14	165	125	96	140	100	76	50	32	
40-125/R	213	118	130	252	112	140	M8	114	160	210	29	80	14	185	145	116	150	110	81	65	40	
40-125/N	213	118	130	252	112	140	M8	114	160	210	29	80	14	185	145	116	150	110	81	65	40	
40-160/R	254	118	165	292	132	160	M10	118	190	240	29	80	14	185	145	116	150	110	81	65	40	
40-160/N	254	118	165	292	132	160	M10	118	190	240	29	80	14	185	145	116	150	110	81	65	40	
40-200/R	294	130	165	340	160	180	M10	115	212	265	25	100	14	185	145	116	150	110	81	65	40	
40-200/N	294	130	165	340	160	180	M10	115	212	265	25	100	14	185	145	116	150	110	81	65	40	
40-200/L	294	130	165	340	160	180	M10	115	212	265	25	100	14	185	145	116	150	110	81	65	40	
50-125/R	254	118	165	292	132	160	M10	114	190	240	25	100	16	185	145	116	165	125	96	65	50	
50-125/N	254	118	165	292	132	160	M10	114	190	240	25	100	16	185	145	116	165	125	96	65	50	
50-160/R	296	130	165	340	160	180	M10	115	115	212	25	100	16	185	145	116	165	125	96	65	50	
50-160/N	296	130	165	340	160	180	M10	115	115	212	25	100	16	185	145	116	165	125	96	65	50	
50-200/R	296	130	165	360	160	200	M10	115	212	265	25	100	16	185	145	116	165	125	96	65	50	
50-200/N	296	130	165	360	160	200	M10	115	212	265	25	100	16	185	145	116	165	125	96	65	50	
50-200/L	296	130	215	360	160	200	M12	115	212	265	25	100	16	185	145	116	165	125	96	65	50	

### 3PF

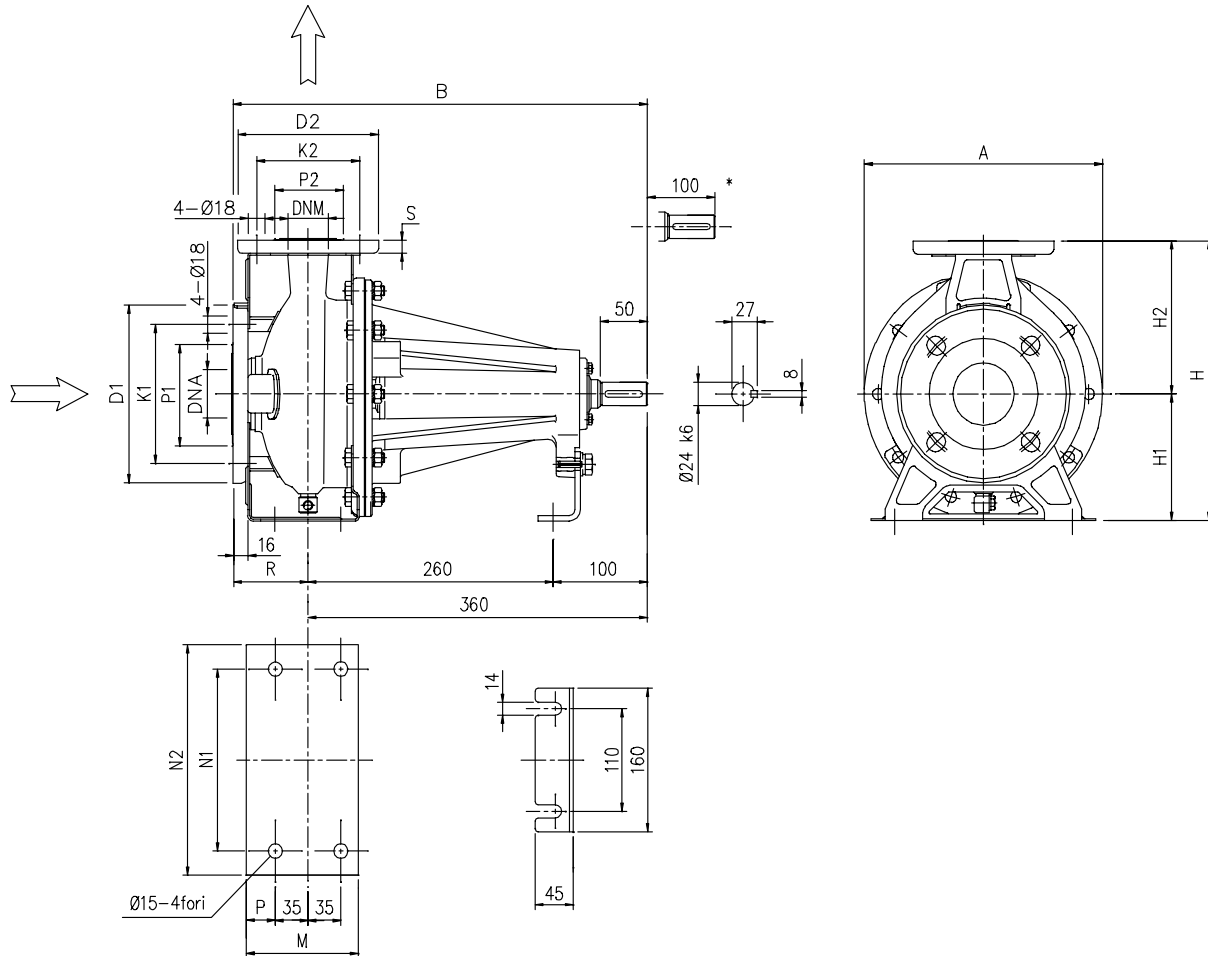

Pump type 3PF	Dimensions (mm)																		Weight kg	
	A	B	H	H1	H2	M	N1	N2	P	R	S	ØD1	ØK1	ØP1	ØD2	ØK2	ØP2	ØDNA		ØDNM
32-125	213	440	252	112	140	114	140	190	29	80	14	165	125	95	140	100	75	50	32	18,0
32-160	254	440	292	132	160	118	190	240	29	80	14	165	125	95	140	100	75	50	32	20,0
32-200	296	440	340	160	180	119	190	240	29	80	14	165	125	95	140	100	75	50	32	28,5
40-125	213	440	252	112	140	114	160	210	29	80	14	185	145	115	150	110	80	65	40	18,0
40-160	254	440	292	132	160	118	190	240	29	80	14	185	145	115	150	110	80	65	40	20,0
40-200	296	460	340	160	180	115	212	265	25	100	14	185	145	115	150	110	80	65	40	29,0
50-125	254	460	292	132	160	114	190	240	25	100	16	185	145	115	165	125	95	65	50	20,0
50-160	296	460	340	160	180	115	212	265	25	100	16	185	145	115	165	125	95	65	50	29,0
50-200	296	460	360	160	200	115	212	265	25	100	16	185	145	115	165	125	95	65	50	29,5

### 3S SERIES COUPLING

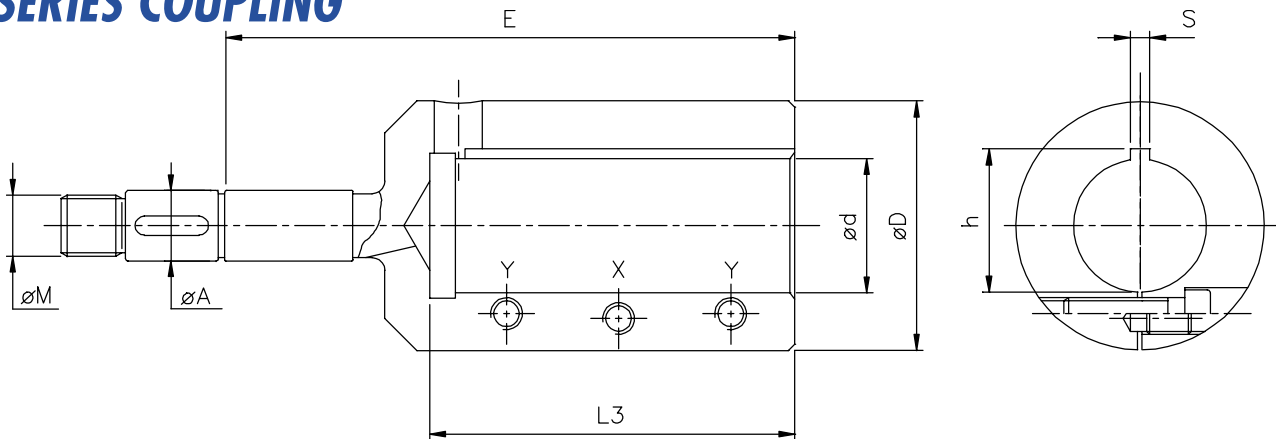

**DIMENSIONAL TABLE**

3SF	Motor		Dimensions (mm)									
	HA	type	D	d	L3	M	X	Y	h	S	E	A
32-125/N	80	B5	41	19	43	M16 x 1.5	M6 x 12	M6 x 20	21.8	6	98	19
32-160/R	90	B5	53	24	53	M16 x 1.5	M8 x 18	M8 x 25	27.3	8	110	19
32-160/N	90	B5	53	24	53	M16 x 1.5	M8 x 18	M8 x 25	27.3	8	110	19
32-200/R	100	B3/5	57	28	63	M16 x 1.5	M8 x 18	M8 x 25	31.3	8	122	19
32-200/N	112	B3/5	57	28	63	M16 x 1.5	M8 x 18	M8 x 25	31.3	8	122	19
32-200/L	132	B3/5	74	38	84	M16 x 1.5	M10 x 25	M10 x 35	41.3	10	145	19
40-125/R	90	B5	53	24	53	M16 x 1.5	M8 x 18	M8 x 25	27.3	8	110	19
40-125/N	90	B5	53	24	53	M16 x 1.5	M8 x 18	M8 x 25	27.3	8	110	19
40-160/R	100	B3/5	57	28	63	M16 x 1.5	M8 x 18	M8 x 25	31.3	8	122	19
40-160/N	112	B3/5	57	28	63	M16 x 1.5	M8 x 18	M8 x 25	31.3	8	122	19
40-200/R	132	B3/5	74	38	84	M16 x 1.5	M10 x 25	M10 x 35	41.3	10	145	19
40-200/N	132	B3/5	74	38	84	M16 x 1.5	M10 x 25	M10 x 35	41.3	10	145	19
40-200/L	160	B3/5	78	42	114	M16 x 1.5	M10 x 25	M10 x 35	45.3	12	178	19
50-125/R	100	B3/5	57	28	63	M16 x 1.5	M8 x 18	M8 x 25	31.3	8	122	19
50-125/N	112	B3/5	57	28	63	M16 x 1.5	M8 x 18	M8 x 25	31.3	8	122	19
50-160/R	132	B3/5	74	38	84	M16 x 1.5	M10 x 25	M10 x 35	41.3	10	145	19
50-160/N	132	B3/5	74	38	84	M16 x 1.5	M10 x 25	M10 x 35	41.3	10	145	19
50-200/R	132	B3/5	74	38	84	M16 x 1.5	M10 x 25	M10 x 35	41.3	10	145	19
50-200/N	160	B3/5	78	42	114	M16 x 1.5	M10 x 25	M10 x 35	45.3	12	178	19
50-200/L	160	B3/5	78	42	114	M16 x 1.5	M10 x 25	M10 x 35	45.3	12	178	22

3SF4	Motor		Dimensions (mm)									
	HA	type	D	d	L3	M	X	Y	h	S	E	A
32-125/N	71	B5	33	14	33	M16 x 1.5	M5 x 10	M5 x 16	16.3	5	88	19
32-160/R	71	B5	33	14	33	M16 x 1.5	M5 x 10	M5 x 16	16.3	5	88	19
32-160/N	71	B5	33	14	33	M16 x 1.5	M5 x 10	M5 x 16	16.3	5	88	19
32-200/R	80	B5	41	19	43	M16 x 1.5	M6 x 12	M6 x 20	21.8	6	98	19
32-200/N	80	B5	41	19	43	M16 x 1.5	M6 x 12	M6 x 20	21.8	6	98	19
32-200/L	80	B5	41	19	43	M16 x 1.5	M6 x 12	M6 x 20	21.8	6	98	19
40-125/R	71	B5	33	14	33	M16 x 1.5	M5 x 10	M5 x 16	16.3	5	88	19
40-125/N	71	B5	33	14	33	M16 x 1.5	M5 x 10	M5 x 16	16.3	5	88	19
40-160/R	80	B5	41	19	43	M16 x 1.5	M6 x 12	M6 x 20	21.8	6	98	19
40-160/N	80	B5	41	19	43	M16 x 1.5	M6 x 12	M6 x 20	21.8	6	98	19
40-200/R	90	B5	53	24	53	M16 x 1.5	M8 x 18	M8 x 25	27.3	8	110	19
40-200/N	90	B5	53	24	53	M16 x 1.5	M8 x 18	M8 x 25	27.3	8	110	19
40-200/L	90	B5	53	24	53	M16 x 1.5	M8 x 18	M6 x 20	27.3	8	110	19
50-125/R	80	B5	41	19	43	M16 x 1.5	M6 x 12	M6 x 20	21.8	6	98	19
50-125/N	80	B5	41	19	43	M16 x 1.5	M6 x 12	M8 x 25	21.8	6	98	19
50-160/R	90	B5	53	24	53	M16 x 1.5	M8 x 18	M8 x 25	27.3	8	110	19
50-160/N	90	B5	53	24	53	M16 x 1.5	M8 x 18	M8 x 25	27.3	8	110	19
50-200/R	90	B5	53	24	53	M16 x 1.5	M8 x 18	M8 x 25	27.3	8	110	19
50-200/N	90	B5	53	24	53	M16 x 1.5	M8 x 18	M8 x 25	27.3	8	110	19
50-200/L	100	B3/5	57	28	63	M16 x 1.5	M8 x 18	M8 x 25	31.3	8	122	22

### 3P SERIES COUPLING

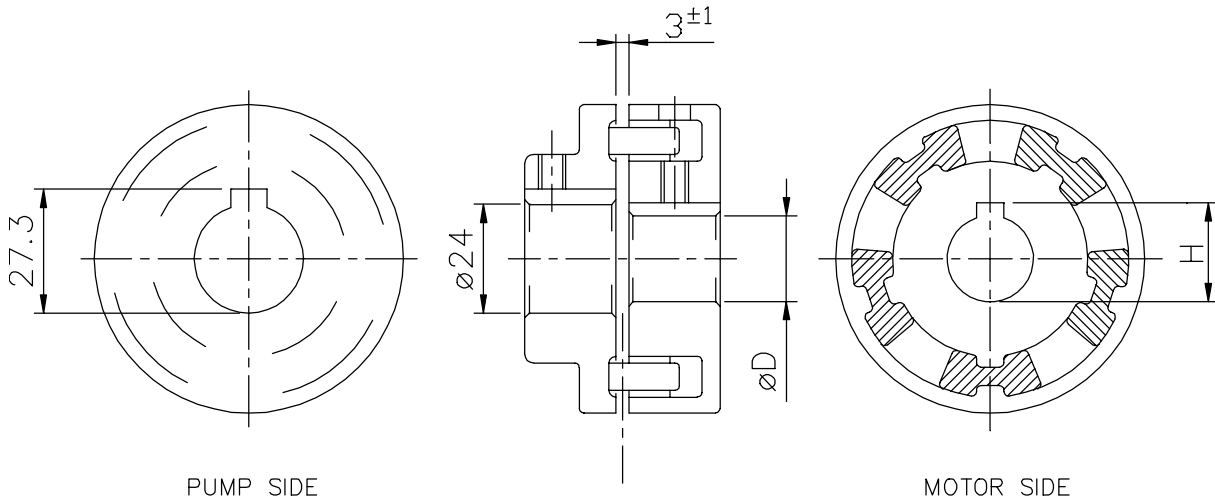

### DIMENSIONAL TABLE

3P	Motor				Dimensions (mm)	
	kW	HP	HA	Type	D	H
32-125/1.1	1.1	1.5	80	B3	19	21.8
32-160/1.5	1.5	2.0	90	B3	24	27.3
32-160/2.2	2.2	3.0	90	B3	24	27.3
32-200/3.0	3.0	4.0	100	B3	28	31.3
32-200/4.0	4.0	5.5	112	B3	28	31.3
32-200/5.5	5.5	7.5	132	B3	28	31.3
40-125/1.5	1.5	2.0	90	B3	24	27.3
40-125/2.2	2.2	3.0	90	B3	24	27.3
40-160/3.0	3.0	4.0	100	B3	28	31.3
40-160/4.0	4.0	5.5	112	B3	28	31.3
40-200/5.5	5.5	7.5	132	B3	38	41.3
40-200/7.5	7.5	10	132	B3	38	41.3
40-200/11	11	15	160	B3	42	45.3
50-125/3.0	3.0	4.0	100	B3	28	31.3
50-125/4.0	4.0	5.5	112	B3	28	31.3
50-160/5.5	5.5	7.5	132	B3	38	41.3
50-160/7.5	7.5	10	132	B3	38	41.3
50-200/9.2	9.2	12.5	132	B3	38	41.3
50-200/11	11	15	160	B3	42	45.3
50-200/15	15	20	160	B3	42	45.3

3P4	Motor				Dimensions (mm)	
	kW	HP	HA	Type	D	H
32-125/0.25	0.25	0.33	71	B3	14	16.3
32-160/0.37R	0.37	0.5	71	B3	14	16.3
32-160/0.37	0.37	0.5	71	B3	14	16.3
32-200/0.55R	0.55	0.75	80	B3	19	21.8
32-200/0.55	0.55	0.75	80	B3	19	21.8
32-200/0.75	0.75	1.0	80	B3	19	21.8
40-125/0.37R	0.37	0.5	71	B3	14	16.3
40-125/0.37	0.37	0.5	71	B3	14	16.3
40-160/0.55R	0.55	0.75	80	B3	19	21.3
40-160/0.55	0.55	0.75	80	B3	19	21.3
40-200/1.1R	1.1	1.5	90	B3	24	27.3
40-200/1.1	1.1	1.5	90	B3	24	27.3
40-200/1.5	1.5	2.0	90	B3	24	27.3
50-125/0.55R	0.55	0.75	80	B3	19	21.3
50-125/0.55	0.55	0.75	80	B3	19	21.3
50-160/1.1R	1.1	1.5	90	B3	24	27.3
50-160/1.1	1.1	1.5	90	B3	24	27.3
50-200/1.5R	1.5	2.0	90	B3	24	27.3
50-200/1.5	1.5	2.0	90	B3	24	27.3
50-200/2.2	2.2	3.0	100	B3	28	31.3